

LENTS TOWN CENTER URBAN RENEWAL PLAN

First Amendment



City of Portland
Portland Development Commission

June 18, 2008

LIST OF PARTICIPANTS

Mayor

Tom Potter

Commissioners

Sam Adams
Randy Leonard
Dan Saltzman
Erik Sten

Portland Development Commission

Mark Rosenbaum, Chair

Sal Kadri
Bertha Ferrán
John Mohlis
Charles Wilhoite

Planning Commission

Don Hanson, President
Michelle Rudd, Vice President
Andre' Baugh
Catherine Ciarlo
Amy Cortese
Larry Hilderbrand
Howard Shapiro
Jill Sherman
Irma Valdez

Lents Town Center Urban Renewal Advisory Committee (URAC)

Leadership

Cora Potter, Chair – At Large Resident
Michael Cummings, Vice Chair – At Large Resident

Organization Representatives

Debbie Black, Foster Area Business Association
Devin Culbertson, Community Partner: Housing Organization – HOST Development
Jess Laventall, Lents Neighborhood Association
Steve Messinetti, Community Partner: Habitat for Humanity:
Roger Rees, Community Partner: Lents Masonic Lodge:
Gary Sargent, 82nd Ave Business Association
Susan Stoltenberg, Community Partner: Portland Impact
Mary Walker, Powellhurst-Gilbert Neighborhood Association

At Large Members

Alan Brzycki, Business
Clint Lenard, Resident
Alan Melton, Resident
Adrian O'Brian, Business

Alternate Members

John Miller, Community Partner: Housing Organization
Rebecca Stevenjord, Lents Neighborhood Association

Lents Town Center Sub Committee on Plan Amendment Study

Cora Potter, Chair, URAC, Resident of Lents Neighborhood
Jess Laventall, URAC, Lents Neighborhood Association
Gary Sargent, URAC, 82nd Avenue of Roses Business Association
Dewey Akers, Chair of Lents Neighborhood Association
Mary Walker, URAC, Resident of Powellhurst-Gilbert Neighborhood
Erica Bjerning, Chair of Foster-Powell Neighborhood Association
Debbie Black, Foster Area Business Association

Portland Development Commission Lents Team

Bob Alexander, Special Projects, Executive Team
Faye Brown, Budget Team
Angela Cadena, Budget Team
Juan Carlos Ocaña-Chíu, Public Participation Coordinator
Margarita Molina, Legal Counsel
Kevin Cronin, AICP, Senior Project Coordinator, Development Department
Sara Culp, Project/Program Coordinator, Housing Department
Diane Hale, Student Employee
Amy Miller Dowell, Lents Town Center URA Development Manager
Byron Estes, Senior Development Manager, Neighborhood URA
Pam Neal, Senior Project Coordinator, Economic Development

Portland Bureau of Planning

Gil Kelley, AICP, Planning Director
Joe Zehnder, Principal Planner
Deborah Stein, Supervising Planner
Barry Manning, Senior Planner
Tom Armstrong, City Planner

Office of Management and Finance

Eric Johansen, Debt Manager
Patty Tigue, Principal Debt Analyst

Consultant Team

Tashman Johnson, LLC
Elaine Howard Consulting, LLC
James Vanden Bos, Planner

TABLE OF CONTENTS

I. INTRODUCTION	1
II. PUBLIC INVOLVEMENT	1
III. GOALS AND OBJECTIVES	1
IV. RELATIONSHIP TO LOCAL PLANS AND OBJECTIVES	1
V. URBAN RENEWAL AREA	24
VI. PROPOSED LAND USES	26
VII. URBAN RENEWAL PROJECTS	26
VIII. PROPERTY ACQUISITION AND DISPOSITION	34
IX. PROPERTY DISPOSITION POLICIES AND PROCEDURES	34
X. RELOCATION POLICIES AND PROCEDURES	34
XI. TAX INCREMENT FINANCING	34
XII. AMENDMENTS TO PLAN	35
EXHIBITS	37

The First Amendment to the Lents Town Center Urban Renewal Plan (the “Amendment”) contains changes to the boundary, maximum indebtedness, an extension of the time to issue maximum indebtedness, and a revision of project activities and financial analysis for the Lents Town Center Urban Renewal Plan (the “Plan”). The Plan for the Lents Town Center Urban Renewal Area (Area) was originally approved by the City Council of the City of Portland on September 9, 1998, by Ordinance No. 172671.

The Lents Plan Amendment Study was authorized by the Portland Development Commission (Commission) Board on April 25, 2007 to conduct a review for a “substantial” plan amendment. Subsequently, Commission staff has been working with the Lents Town Center Urban Renewal Advisory Committee (URAC), a subcommittee, and consultants to develop technical, legal, and financial information so that community stakeholders and policy makers could make an informed decision regarding the future of the Area.

As part of a larger Commission evaluation of urban renewal districts referred to as the “Future of Urban Renewal,” the Area is one of the first in a series of studies that began in 2007 to determine the financial capacity, policy choices, and a range of needed projects in each participating urban renewal area. The purpose of this Amendment is to provide a clear and concise record of technical, legal, and financial research, data, findings, and deliberations regarding the plan amendment study process that led to the development of a preferred recommendation and a final decision. This amendment includes the following changes to the original Plan:

- A. An extended timeline for the issuance of bonds and funding for urban renewal activities.**
- B. Expanded boundaries for the Area.**
- C. An increase in maximum indebtedness and new financial projections for the Area.**
- D. Additional projects included in the Plan.**
- E. An update to section IV detailing Relationship to Local Objectives.**
- F. An update to section XII Amendments to the Plan.**

This urban renewal plan, as amended, has been prepared by the Urban Renewal Agency of the City of Portland, Oregon, pursuant to Oregon Revised Statutes (ORS) Chapter 457, the Oregon Constitution, and all applicable laws and ordinances of the State of Oregon and City of Portland, respectively. All such applicable laws are made a part of this Plan, whether expressly referred to in the text or not.

The amended Plan would be administered by the Commission, which was established by the citizens of Portland through a vote in 1958 as the City’s Urban Renewal Agency. Changes to the

Plan, if necessary, must comply with Section XII of this Plan, and if a substantial change, must be approved by the Commission and then by the City Council. The Amendment is accompanied by an Urban Renewal Report (the "Report") that contains additional information.

The last date for issuance of maximum indebtedness is June 30, 2020. The maximum amount of indebtedness (amount of tax increment financing for projects and programs) that may be issued for the Plan is two hundred, forty-five million dollars (\$245,000,000).

I. INTRODUCTION

The Expansion Areas shown in Exhibit II, consist of approximately 205 acres of land. This Expansion Areas are contiguous to the existing Area and mostly comprises commercially zoned property on and directly adjacent to SE Foster Road from SE 50th Avenue to SE 79th Avenue, commercial nodes along SE 122nd Avenue, job creation opportunity sites along SE Powell Boulevard, Marysville School and Alice Ott Middle School, housing opportunity sites on SE Knapp Street and SE 122nd Avenue and the Leach Botanical Gardens.

The overall purpose of the Amendment is to use tax increment financing to overcome obstacles to development of the Area. Tax increment financing (see section XI) generally means that the property taxes resulting from growth in property value within the Area can be used to finance improvement projects and programs.

II. PUBLIC INVOLVEMENT

No change.

III. GOALS AND OBJECTIVES

No change.

IV. RELATIONSHIP TO LOCAL PLANS AND OBJECTIVES

The language in this section IV replaces the corresponding section IV in the existing Plan in its entirety.

The Plan will play a critical role in achieving the goals, policies, and objectives of the Portland Comprehensive Plan, the Outer Southeast Community Plan, and applicable neighborhood plans. The purpose of this section is to meet the statutory requirements for land use planning consistency under ORS 457.095(3). This section is organized by each land use document with the Portland Comprehensive Plan as the parent and all other documents as subordinate and supporting of the overall goals and policies enumerated in a comprehensive plan. Specifically, the Plan will provide for urban renewal projects and programs that help to implement the City of Portland's plans and policies that seek to preserve and reinforce the stability and diversity of the City's neighborhoods while allowing for increased density in order to attract and retain long-term residents and businesses and insure the City's residential quality and economic vitality.

As shown in Table 1, the Plan goals and objectives support corresponding Portland Comprehensive Plan policies and in turn the comprehensive plan is acknowledged by the Land Conservation and Development Commission (LCDC) as consistent with Oregon Land Use Planning Goals and Policies. The Plan has been formulated through a public involvement process that is consistent with the Citizen Involvement (Goal 9) and Metropolitan Coordination (Goal 1) policies. The neighborhood and commercial area revitalization goals are consistent with city and regional goals to reinvest and redirect growth and development into existing urban areas. The Plan will facilitate redevelopment and public improvements that will provide a range of

commercial, employment and housing opportunities in the Lents Town Center, three station communities (Powell, Holgate, and Flavel) along the South Corridor/I-205 light rail transit line, and three main street segments (82nd Avenue, Foster Road and 122nd Avenue).

The Plan also will help provide housing and employment opportunities. The creation and maintenance of a variety of housing choices for residents of all income levels is an important goal found in the Portland Comprehensive Plan and supporting documents. This goal clearly is supported by the identified housing projects in the Plan. Encouraging job creation is another goal that is supported by urban renewal projects such as developing the Johnson Creek Industrial Area (Freeway Land site) and the area along Powell Boulevard south of Kelly Butte for a wider range of employment uses.

The Plan includes a range of transportation improvement projects that will help provide a range of transportation choices and enhance connectivity that will reinforce the livability of neighborhoods and the vitality of commercial areas. The Plan will facilitate the redevelopment of an area that is well served by transit, which will reduce the need for employees and customers to rely on automobile travel; and reduce air pollution and traffic congestion on the City's street system.

The Plan also supports policies that call for providing parks and open spaces to meet recreational needs; creating a sense of connection with the natural environment; and protecting natural resources by reducing the impact of development. Specifically, the Plan addresses floodplain and other environmental issues so that industrial and commercial uses do not have an adverse impact on the Johnson Creek watershed and surrounding wetlands.

The Plan is supportive of the six neighborhood plans that encompass the Area. The Creston-Kenilworth, Foster-Powell and Mt. Scott-Arleta neighborhood plans all emphasize the Foster Road corridor as an important part of the community identity and the need to support it as a pedestrian-friendly main street. The Lents neighborhood plan strongly supports revitalization of the Lents Town Center and focusing public resources on the development of the town center as a commercial, residential, and employment center, which is consistent with the goals of the Plan. The Brentwood-Darlington and Powellhurst-Gilbert neighborhood plans emphasize improving the physical appearance of the neighborhood, improving commercial viability, and residential diversity, which are all consistent with the goals and projects included in the Plan.

Appendix A provides findings of fact for consistency with applicable state, regional, and local planning goals, policies, and objectives.

A. Portland Comprehensive Plan

Effective on January 1, 1981 and last revised in July 2006, the City of Portland's Comprehensive Plan is a guide for all land use related development within the City. The Plan is especially supportive of the following Comprehensive Goals and Policies.

GOAL 2 URBAN DEVELOPMENT

Maintain Portland's role as the major regional employment, population and cultural center through public policies that encourage expanded opportunity for housing and jobs, while retaining the character of established residential neighborhoods and business centers.

POLICIES

Policy 2.1 Population Growth

Allow for population growth within the existing city boundary by providing land use opportunities that will accommodate the projected increase in city households by the year 2000.

Policy 2.2 Urban Diversity

Promote a range of living environments and employment opportunities for Portland residents in order to attract and retain a stable and diversified population.

Policy 2.9 Residential Neighborhoods

Allow for a range of housing types to accommodate increased population growth while improving and protecting the city's residential neighborhoods.

Policy 2.11 Commercial Centers

Expand the role of major established commercial centers which are well served by transit. Strengthen these centers with retail, office, service and labor-intensive industrial activities which are compatible with the surrounding area.

Policy 2.12 Transit Corridors

Provide a mixture of activities along major transit routes and Main Streets to support the use of transit. Encourage development of commercial uses and allow labor-intensive industrial activities which are compatible with the surrounding area. Require development along transit routes to relate to the transit line and pedestrians and to provide on-site pedestrian connections.

Policy 2.15 Living Closer to Work

Locate greater residential densities near major employment centers, including Metro designated regional and town centers, to reduce vehicle miles traveled per capita and maintain air quality. Locate affordable housing close to employment centers. Encourage home-based work where the nature of the work is not disruptive to the neighborhood.

Policy 2.17 Transit Stations and Transit Centers

Encourage transit-oriented development patterns at transit stations and at transit centers to provide for easy access to transit service. Establish minimum residential densities on residentially-zoned lands within one-half mile of transit stations and one-quarter mile of transit centers that support the use of transit. The design and mix of land uses surrounding transit stations and transit centers should emphasize a pedestrian- and bicycle-oriented environment and support transit use.

Policy 2.28 Outer Southeast Community Plan

Promote the economic vitality, diverse residential character, environmental quality, and livability of Outer Southeast Portland by including the Outer Southeast Community Plan as a part of this Comprehensive Plan.

GOAL 3 NEIGHBORHOODS

Preserve and reinforce the stability and diversity of the City's neighborhoods while allowing for increased density in order to attract and retain long-term residents and businesses and insure the City's residential quality and economic vitality.

POLICIES

Policy 3.1 Physical Conditions

Provide and coordinate programs to prevent the deterioration of existing structures and public facilities.

Policy 3.2 Social Conditions

Provide and coordinate programs to promote neighborhood interest, concern and security and to minimize the social impact of land use decisions.

Policy 3.5 Neighborhood Involvement

Provide for the active involvement of neighborhood residents and businesses in decisions affecting their neighborhood through the promotion of neighborhood and business associations.

Policy 3.6 Neighborhood Plan

Maintain and enforce neighborhood plans that are consistent with the Comprehensive Plan and that have been adopted by City Council.

Policy 3.9 Outer Southeast Community Plan Neighborhoods and Business Plan include as part of the Comprehensive Plan neighborhood and business plans developed as part of the Outer Southeast Community Plan. Neighborhood and business plans developed as part of the Outer Southeast Community Plan are those for Centennial, Foster-Powell, Hazelwood, Lents, Mt. Scott-Arleta, Mill Park, Montavilla, Outer Southeast Business Coalition, Pleasant Valley, Powellhurst-Gilbert, and South Tabor. Use the Neighborhood

Plans to guide decisions on land use, transportation and capital expenditures, community development programs, where applicable.

Objective B. Ensure that Foster-Powell remains a stable, diverse, affordable community whose residents include both young families and older households. Maintain its unique sense of place by preserving its historic housing and streetcar era commercial and institutional buildings. Use the Foster-Powell Neighborhood Plan as a guide to future decisions on land use, capital improvement projects, and community development activities.

Objective AD. Foster Lents as a thriving urban employment center where people enjoy living, working, and recreating.

Objective E. Enhance the community pride, safety, residential quality, and accessibility of the Mt. Scott Arleta Neighborhood.

Objective H. Enhance the image, marketability, and vitality of businesses and business areas in Outer Southeast. Use the Southeast Business Plan to guide decisions on land use, transportation, capital expenditures, and economic revitalization programs.

Objective J. Make the Powellhurst-Gilbert Neighborhood an enjoyable and pleasant place to live by improving the physical appearance of the neighborhood, improving commercial viability, and residential diversity.

GOAL 4 HOUSING

Enhance Portland's vitality as a community at the center of the region's housing market by providing housing of different types, tenures, density, sizes, costs, and locations that accommodate the needs, preferences, and financial capabilities of current and future households.

POLICIES

Policy 4.3 Sustainable Housing

Encourage housing that supports sustainable development patterns by promoting the efficient use of land, conservation of natural resources, easy access to public transit and other efficient modes of transportation, easy access to services and parks, resource efficient design and construction, and the use of renewable energy resources.

Objective A. Place new residential developments at locations that increase potential ridership on the regional transit system and support the Central City as the region's employment and cultural center.

Objective B. Establish development patterns that combine residential with other compatible uses in mixed-use areas such as the Central City, Gateway Regional Center, Station Communities, Town Centers, Main Streets, and Corridors.

Objective C. Encourage the development of housing at transit-supportive densities near transit streets, especially where parks or schools are present, to ensure that the benefits of the public's investment in those facilities are available to as many households as possible.

Policy 4.4 Housing Safety

Ensure a safe and healthy built environment and assist in the preservation of sound existing housing and the improvement of neighborhoods.

Policy 4.5 Housing Conservation

Restore, rehabilitate, and conserve existing sound housing as one method of maintaining housing as a physical asset that contributes to an area's desired character.

Policy 4.7 Balanced Communities

Strive for livable mixed-income neighborhoods throughout Portland that collectively reflect the diversity of housing types, tenures (rental and ownership) and income levels of the region.

Objective A. Achieve a distribution of household incomes similar to the distribution of household incomes found citywide, in the Central City, Gateway Regional Center, in town centers, and in large redevelopment projects.

Objective B. Maintain income diversity within neighborhoods by 1) allowing a mix of housing types and tenures, including houses, houses on smaller lots, small houses, duplexes, attached housing, accessory dwelling units, multi-dwelling housing, and mixed-use developments; and 2) ensure that income diversity is maintained over the long-term.

Objective C. Promote the development of mixed-income housing that may include a mix of housing types.

Objective D. Encourage housing opportunities for extremely low and very low-income households (below 50% MFI) in all neighborhoods to avoid their concentration in any one area.

Objective F. Support public and private actions that improve the physical and social environment of areas that have experienced disinvestment in housing, that have a concentration of low-income households, or that lack infrastructure.

Objective G. Encourage the development and preservation of housing that serves a range of household income levels at locations near public transit and employment opportunities.

Objective H. Improve the balance in the city's population by attracting a proportionate share of the region's families with children in order to encourage stabilized neighborhoods and a vital public school system.

Objective I. Expand homeownership opportunities for existing residents in neighborhoods with homeownership rates lower than the regional average.

Objective J. Expand multi-dwelling and rental housing opportunities in neighborhoods with homeownership rates higher than the regional average.

Objective K. As neighborhoods evolve, discourage the involuntary displacement of low-income residents from their community, while expanding housing opportunities to create more balanced communities.

Policy 4.10 Housing Diversity

Promote creation of a range of housing types, prices, and rents to 1) create culturally and economically diverse neighborhoods; and 2) allow those whose housing needs change to find housing that meets their needs within their existing community.

Objective A. Keep Portland inviting to households with children by ensuring through public and private action the availability of housing that meets their needs throughout the city.

Objective B. Support homeownership opportunities in new multi-dwelling housing by encouraging the creation of condominiums, cooperatives, mutual housing associations, and limited equity cooperatives.

Objective C. Accommodate a variety of housing types that are attractive and affordable to potential homebuyers at all income levels.

Objective D. Encourage the production of a range of housing types for the elderly and people with disabilities, including but not limited to independent living, assisted living, and skilled nursing care facilities.

Objective E. Support opportunities for renter households by providing a range of housing types, sizes, and rent levels throughout the city.

Objective F. Increase the public school population in Portland, preventing widespread school closures, and the consequent underutilization of public facilities.

Policy 4.11 Housing Affordability

Promote the development and preservation of quality housing that is affordable across the full spectrum of household incomes.

Objective A. Include strategies and actions that encourage the provision of housing affordable to all income levels in neighborhood, and community plans, and other area plans that pertain to housing.

Objective B. Ensure the availability of housing that meets the needs of all Portland households.

Objective D. Promote conservation programs and energy-efficient practices and programs that reduce housing operating costs for energy, sewer, and water usage.

Objective E. Work in partnership with the Housing Authority of Portland to preserve its portfolio of federally assisted housing at rents levels affordable to extremely and very low-income households.

Objective F. Pursue adequate financial resources to develop, maintain and preserve housing and housing assistance programs for households whose needs are not met by the housing market.

Policy 4.12 Housing Continuum

Ensure that a range of housing from temporary shelters, to transitional, and to permanent housing for renters and owners is available, with appropriate supportive services for those who need them.

Objective A. Plan and coordinate the provision of housing opportunities for households whose needs are not met by the private for-profit market.

Objective B. Promote the preservation and development of a sufficient supply of transitional and permanent housing affordable to extremely low-income individuals and households with children in order to reduce or prevent homelessness.

Objective C. Provide opportunities throughout the city for emergency shelters and transitional housing for people who are homeless.

Objective D. Stimulate production of a variety of housing types that are affordable and responsive to the needs of very low, low, moderate, and middle-income households.

Objective E. Expand opportunities for first-time homebuyers.

Policy 4.14 Neighborhood Stability

Stabilize neighborhoods by promoting: 1) a variety of homeownership and rental housing options; 2) security of housing tenure; and 3) opportunities for community interaction.

Objective A. Promote and maintain homeownership options within neighborhoods.

Objective B. Promote housing opportunities that build a sense of community, civic involvement and neighborhood pride.

Objective C. Protect, preserve, and restore the City's single-room occupancy (SRO) and low-income housing.

Objective D. Encourage the retention of existing rental housing at rent levels affordable to area residents.

Objective E. Increase opportunities for construction, acquisition, or preservation of housing affordable to area residents in locations where rising property values and gentrification contribute to their involuntary displacement.

Objective K. Enhance the quality of the design of new infill residential development.

GOAL 5 ECONOMIC DEVELOPMENT

Foster a strong and diverse economy that provides a full range of employment and economic choices for individuals and families in all parts of the city.

POLICIES

Policy 5.1 Urban Development and Revitalization

Encourage investment in the development, redevelopment, rehabilitation and adaptive reuse of urban land and buildings for employment and housing opportunities.

Policy 5.2 Business Development

Sustain and support business development activities to retain, expand and recruit businesses.

Policy 5.3 Community-Based Economic Development

Support community-based economic development initiatives consistent with this Comprehensive Plan and compatible with neighborhood livability.

Policy 5.5 Infrastructure Development

Promote public and private investments in public infrastructure to foster economic development in Council-designated target areas.

Policy 5.6 Area Character and Identity Within Designated Commercial Areas
Promote and enhance the special character and identity of Portland's designated commercial areas.

Policy 5.7 Business Environment within Designated Commercial Areas
Promote a business environment within designated commercial areas that is conducive to the formation, retention and expansion of commercial businesses.

Policy 5.8 Diversity and Identity in Industrial Areas
Promote a variety of efficient, safe and attractive industrial sanctuary and mixed employment areas in Portland.

Objective E. Create mixed employment areas which encourage a broad range of employment opportunities by permitting a mix of industrial and commercial activities. Prevent land use conflicts within the mixed employment areas through the use of development standards and by limiting conflicting types of development.

GOAL 6 TRANSPORTATION

Develop a balanced, equitable, and efficient transportation system that provides a range of transportation choices; reinforces the livability of neighborhoods; supports a strong and diverse economy; reduces air, noise, and water pollution; and lessens reliance on the automobile while maintaining accessibility.

POLICIES

Policy 6.19 Transit-Oriented Development
Reinforce the link between transit and land use by encouraging transit-oriented development and supporting increased residential and employment densities along transit streets, at existing and planned light rail transit stations, and at other major activity centers.

Policy 6.20 Connectivity
Support development of an interconnected, multimodal transportation system to serve mixed-use areas, residential neighborhoods, and other activity centers.

Objective A. Provide interconnected local and collector streets to serve new and redeveloping areas and to ensure safe, efficient, and convenient pedestrian, bicycle, and vehicle access with preference for public streets over private streets.

Objective B. Create short blocks through development of frequent street connections in mixed-use areas of planned high-density development.

Objective C. Provide convenient and safe bicycle and pedestrian connections to transit routes, schools, and parks, as well as within and between new and existing residential developments, employment areas, and other activity centers where street connections are not feasible.

Policy 6.22 Pedestrian Transportation

Plan and complete a pedestrian network that increases the opportunities for walking to shopping and services, institutional and recreational destinations, employment, and transit.

Policy 6.23 Bicycle Transportation

Make the bicycle an integral part of daily life in Portland, particularly for trips of less than five miles, by implementing a bikeway network, providing end-of-trip facilities, improving bicycle/transit integration, encouraging bicycle use, and making bicycling safer.

Policy 6.37 Southeast Transportation District

Reduce travel demand and reliance on the automobile in Southeast Portland to protect residential areas and industrial sanctuaries from non-local traffic, while maintaining access to established commercial areas.

Objective F. Recognize SE Foster's (west of I-205) importance as a main street and as a Major City Traffic Street and Major City Transit Street by improving the pedestrian environment, preserving on-street parking, facilitating transit movement, and adding street trees.

Objective M. Implement transportation improvements identified in the Lents Urban Renewal Plan that will revitalize its commercial core and environs.

Policy 6.38 Far Southeast Transportation District

Address transportation issues in the Far Southeast District by encouraging the use of transit and demand management measures, improving pedestrian/bicycle access, creating a more connected street system, and improving the functioning of arterials.

Objective A. Consider existing and future land use patterns, environmental impacts, the need for additional connectivity of collectors, and transit accessibility when improvements are planned and designed for the arterial system, particularly SE Powell and SE Foster.

Objective B. Improve arterials through better signalization and intersection design to serve adjacent land uses and to provide for access to adjacent neighborhoods, while minimizing non-local traffic on local streets.

Objective C. Accommodate bicyclists and pedestrians along arterials and at crossings, especially at activity nodes, through a combination of street and traffic management improvements.

Objective F. Provide adequate street connections in the Far Southeast District through the development and implementation of master street plans that identify connections for vehicles, pedestrians, and bicyclists.

Objective H. Implement transportation improvements identified in the Lents Urban Renewal Plan that will revitalize its commercial core and environs.

Objective J. Improve pedestrian access at the light rail transit stations by adding local street connections and improvements, including enhanced crossings and wider sidewalks.

GOAL 8 ENVIRONMENT

Maintain and improve the quality of Portland's air, water and land resources and protect neighborhoods and businesses centers from detrimental noise pollution.

POLICIES

Policy 8.11 Special Areas

Recognize unique land qualities and adopt specific planning objectives for special areas.

Objective D. Johnson Creek Basin: Protect and preserve the scenic, recreation, fishery, wildlife, flood control, water quality, and other natural resource values of the Johnson Creek basin through application of environmental overlay zones and implementation of the Johnson Creek Basin Protection Plan.

Policy 8.14 Natural Resources

Conserve significant natural and scenic resource sites and values through a combination of programs which involve zoning and other land use controls, purchase, preservation, intergovernmental coordination, conservation, and mitigation. Balance the conservation of significant natural resources with the need for other urban uses and activities through evaluation of economic, social, environmental, and energy consequences of such actions.

GOAL 9 CITIZEN INVOLVEMENT

Improve the method for citizen involvement in the on-going land use decision-making process and provide opportunities for citizen participation in the implementation, review and amendment of the adopted Comprehensive Plan.

POLICIES

Policy 9.1 Citizen Involvement Coordination

Encourage citizen involvement in land use planning projects by actively coordinating the planning process with relevant community organizations, through the reasonable availability of planning reports to city residents and businesses, and notice of official public hearings to neighborhood associations, business groups, affected individuals and the general public.

GOAL 11A PUBLIC FACILITIES

Provide a timely, orderly and efficient arrangement of public facilities and services that support existing and planned land use patterns and densities.

POLICIES

Policy 11.1 Service Responsibility

Within its boundaries of incorporation, the City of Portland will provide, where feasible and as sufficient funds are available from public or private sources, the following facilities and services at levels appropriate for all land use types:

1. streets and other public ways
2. sanitary and stormwater sewers
3. police protection
4. fire protection
5. parks and recreation
6. water supply
7. planning, zoning, buildings and subdivision control

GOAL 11B PUBLIC RIGHTS-OF-WAY

Improve the quality of Portland's transportation system by carrying out projects to implement the 2040 Growth Concept, preserving public rights-of-way, implementing street plans, continuing high-quality maintenance and improvement programs, and allocating limited resources to identified needs of neighborhoods, commerce, and industry.

POLICIES

Policy 11.9 Project Selection

Through the capital improvement program process, give priority consideration to transportation projects that will contribute to a reduction in vehicle miles traveled per capita, while supporting economic vitality and sustainability.

Objective A. Promote a compact urban form by supporting development in high-priority 2040 Growth Concept areas, including facilities and improvements that support mixed-use, pedestrian-friendly development and increase walking, bicycling, and transit use.

Objective B. Address existing deficiencies or hazards by improving pedestrian, bicycle, and vehicular safety.

Objective C. Use good resource management and minimize or reduce negative impacts to the natural environment.

Objective D. Provide and improve access to and within activity centers and develop safe routes to schools.

Objective E. Improve access to existing and emerging employment and industrial areas.

Policy 11.11 Street Plans

Promote a logical, direct, and connected street system through the development of street plans.

Objective L. As the Far Southeast District develops, provide connectivity for all modes of travel by developing streets.

Goal 11F Parks and Recreation

Maximize the quality, safety and usability of parklands and facilities through the efficient maintenance and operation of park improvements, preservation of parks and open space, and equitable allocation of active and passive recreation opportunities for the citizens of Portland.

GOAL 11I SCHOOLS

Enhance the educational opportunities of Portland's citizens by supporting the objectives of Portland School District #1 and adjacent districts through assistance in planning educational facilities.

POLICIES

Policy 11.56 Maximize Investments

Support school district facility and program investments in redeveloping neighborhoods through the City's allocation of housing assistance and park improvement investments.

Policy 11.57 Safety

Provide traffic improvements, such as sidewalks and bikeways, to promote safe routes to schools where attendance area reorganization requires longer travel distances for students.

GOAL 12 URBAN DESIGN

Enhance Portland as a livable city, attractive in its setting and dynamic in its urban character by preserving its history and building a substantial legacy of quality private developments and public improvements for future generations.

POLICIES

Policy 12.2. Enhancing Variety

Promote the development of areas of special identity and urban character. Portland is a city built from the aggregation of formerly independent settlements. The City's residential, commercial and industrial areas should have attractive identities that enhance the urbanity of the City.

Policy 12.6 Preserve Neighborhoods

Preserve and support the qualities of individual neighborhoods that help to make them attractive places. Encourage neighborhoods to express their design values in neighborhood and community planning projects. Seek ways to respect and strengthen neighborhood values in new development projects that implement this Comprehensive Plan.

B. Outer Southeast Community Plan

Economic Development Policy

Improve the vitality of outer southeast business districts and employment centers. Ensure that they grow to serve the needs of outer southeast residents, attract customers from throughout the region, and generate family wage jobs for residents.

OBJECTIVES

Objective 1. Foster the revitalization of older business districts including Foster Road, 82nd Avenue, and the former downtowns of Lents and Montavilla.

Objective 2. Promote the reuse and redevelopment of vacant, underused, or dilapidated commercial sites on arterials along both sides of I-205.

Objective 3. Create up to 6,000 new jobs in the outer southeast area by encouraging development of commercial and industrial areas.

e. Encourage the development of the Lents town center at the I-205/Foster Road interchange.

Objective 4. Promote the retention and growth of existing businesses to increase the number of jobs they provide.

Objective 5. Recruit businesses that provide family-wage jobs.

Transportation Policy

Ensure that streets in outer southeast form a network that provides for efficient travel throughout the community and to other parts of Portland and the region. Reduce congestion and pollution caused by the automobile by creating land use patterns that support transit, bike, and pedestrian travel.

OBJECTIVES

Objective 1. Reduce the amount of automobile driving done by area residents by making it more convenient to use public transit.

b. Encourage a mix of multifamily housing and shipping opportunities in areas with good transit service.

Objective 2. Support better mass transit service by creating opportunities to develop higher-density housing on or near streets with public-transit service or planned public-transit service. Ensure that this housing blends in with that of surrounding residential areas.

Objective 4. Pursue and plan for high-capacity transit on I-205, with a Lents station.

Objective 5. Increase housing densities where streets cross I-205 to support development of a future high capacity transit facility such as a light-rail line or express bus service.

Housing Policy

Provide a variety of housing choices for outer southeast community residents of all income levels by maintaining the existing sound housing stock and promoting new housing development.

OBJECTIVES

Objective 2. Stimulate production of new housing units by both private and nonprofit housing producers to accommodate expected population growth.

Objective 6. Encourage property owners to maintain and improve their homes so that established neighborhoods remain stable and attractive.

Objective 7. Preserve and increase the supply of housing affordable to households below the median income.

Open Space and Environmental Policy

Provide parks and open spaces to meet projected recreational needs of outer southeast residents. Create a sense of connection with the natural environment. Protect natural resources by reducing the impact of development on them.

OBJECTIVES

Objective 2. Reinforce Johnson Creek, the Boring Lava Hills, and Kelly Butte as significant natural and scenic resources.

Objective 3. Improve access to sites for recreational and open space opportunities, especially in the riparian areas of the Johnson Creek corridor.

Objective 4. Establish a network of bicycle and pedestrian connections between outer southeast's parks, open spaces, and the Springwater Corridor.

Objective 5. Ensure convenient access from residential areas to neighborhood parks.

Objective 6. Protect and enhance the Springwater Corridor as a recreational trail.

Objective 7. Protect and improve water quality with the Johnson Creek Basin.

Objective 8. Maintain Johnson Creek and all related waterways in as natural condition as possible.

Urban Design Policy

Foster a sense of place and identity for the Outer Southeast Community Plan area by reinforcing existing character-giving elements and encouraging the emergence of new ones as envisioned in the Vision Plan section of the Outer Southeast Community Plan.

OBJECTIVES

Objective 2. Establish a "town center" at Lents. Promote mixed-use development with a streetscape that provides pedestrian amenities. Reinforce the existing pedestrian district at Lents.

Objective 4. Promote "main street" development on portions of SE Foster Road, SE Glisan Street, and SE Woodstock Boulevard, on SE Division and SE Stark Streets, and SE 82nd and SE 122nd Avenues. Locate buildings with entrances off the sidewalk. Encourage sidewalk cafés, display windows, benches, street trees, awnings, small scale signs that are directed to the pedestrians, and on-street parking.

Objective 6. Embrace urban design proposals as put forth in each Outer Southeast Community Neighborhood Plan.

Objective 7. Promote a street network which reinforces the unique character of each subarea.

Subarea Policy I

Traditional Urban Neighborhoods (west of 82nd Avenue)

Preserve the fabric of these traditional residential neighborhoods and streetcar era commercial districts. Promote construction of new housing on or near transit streets and “Main Street” development on portions of Foster Road, Stark, and Glisan Streets. Encourage infill development.

Objective 1. Encourage "Main Street" development on Foster Road between Holgate and 72nd Avenues, Stark Street between 78th and 82nd Avenues, and Glisan Street between 68th and 80th.

Objective 3. Create opportunities for new multifamily housing along streets with transit service.

Objective 4. Encourage compatible infill at densities which support transit on vacant lots in established residential areas.

Subarea Policy II

82nd Avenue/I-205 Corridor

Promote revitalization of 82nd Avenue. Increase the number and variety of jobs provided in these areas. Enlarge the market for local retail and service businesses by increasing housing opportunity.

Objective 1. Allow industrial as well as commercial uses at 82nd Avenue and Foster Road and improve the appearance of this node.

Objective 2. Allow a greater range of employment uses in the area south of Foster along 82nd Avenue.

Objective 6. Create opportunity for higher-density residential development along transit streets and in areas with vacant residential land.

Subarea Policy III

Lents Town Center

Foster the development of a Lents Town Center that attracts employment opportunities, residential density, and recreational activities while reducing adverse environmental impacts.

Objective 2. Focus public resources on the development of the Town Center as a commercial, residential and employment center.

Objective 3. Address flood plain and other environmental issues so that industrial and commercial uses do not have an adverse impact on Johnson Creek and surrounding wetlands.

Objective 4. Ensure a wide range of housing in terms of structure, ownership, rental patterns, and price.

Objective 5. Provide a coordinated pedestrian, bicycle, automobile, and transit infrastructure that will support increased economic and residential development.

Subarea Policy VII

Mixed-Era Neighborhoods

Provide for the orderly development of new housing at urban densities and ensure that residential areas are served by convenient neighborhood commercial centers and transit.

Objective 1. Increase the single-family housing opportunity in areas where there are large lots and vacant properties suitable for development.

Objective 4. Promote new streets that form a network that accommodates an efficient development pattern, regular lot patterns, multi-modal capability, and multiple access for emergency vehicles.

Objective 7. Develop the area along Powell Boulevard south of Kelly Butte for a wider range of employment uses.

Objective 9. Reduce the potential for flooding and water quality problems.

Subarea Policy VIII

Mt. Scott/Johnson Creek

Protect the natural character of the area while providing for orderly urban development. Provide for the recreational needs of this newly developing area and locate new housing opportunity near Powell Butte.

C. Outer Southeast Business Plan

POLICIES AND OBJECTIVES

Policy 1. Promotion and Revitalization of Businesses and Institutions

Encourage expansion and revitalization of existing businesses and institutions in order to create an environment attractive to new development.

Objective 1. Rebuild and develop Outer Southeast commercial and business areas into vital thriving community that will encourage further business expansion and development, aid in its orderly growth, and create a positive image.

Objective 3. Work closely with residents and neighborhood associations to increase the livability of the Outer Southeast area and the standard of living of its residents.

Objective 6. Encourage residential development which supports the existing, improved and growing business community.

Policy 3. Traffic and Transportation

Provide a safe, efficient and attractive, full-service transportation system to serve Outer Southeast business areas.

Objective 1. Support the provision of a High Capacity Transit system along the I-205 corridor from the Airport to Clackamas Town Center and Oregon City.

Objective 3. Increase the livability and the viability of businesses in the district by improving traffic flow, parking and streets.

Objective 8. Promote design alternatives which improve the street image through a variety of means, such as street trees, signs, utility locations and landscaping.

Policy 4. Target Areas

Provide an effective business environment by providing opportunities for established businesses to expand or reinforce their uses at existing locations.

D. Lents Neighborhood Plan

POLICIES

Policy 2. Economic Development

Preserve and enhance the commercial viability of existing businesses within Lents area.

Policy 3. Trails, Parks, Open Space and the Environment

Promote recreational opportunities in and around Lents while preserving and protecting the environment.

Policy 5. Urban Design

Use urban design concepts and amenities to preserve and enhance neighborhood livability and to maintain a sense of place.

Policy 6. Housing

Encourage a sense of community pride in Lents by maintaining, restoring and rehabilitating existing homes and taking advantage of opportunities to build a variety of new housing.

Policy 7. Neighborhood Livability

Restore Lents identity as a friendly, safe, attractive neighborhood for everyone in our historic community.

Objective 1. Maintain existing community resources and establish others such as community center, library, historical mini museum, mini parks, community garden, mini precinct and senior center.

Policy 8. Transportation

Improve access to and through Lents using a variety of modes while reducing noise, pollution and safety hazards.

E. Foster-Powell Neighborhood Plan

POLICIES

Policy 4. Housing

Ensure an adequate supply of housing at a variety of prices and rents by promoting new home ownership opportunities, improvement of the existing housing stock, responsible rental property ownership, and the development of compatible infill housing.

Policy 6. Transportation

Reduce the speed and volume of traffic on local streets so that they area safe for pedestrians and bicyclists. Provide safe access across the arterials that surround the neighborhood.

Policy 7. Commercial Areas

Improve the Foster Road and 82nd Avenue commercial areas. Encourage businesses that serve Foster-Powell and surrounding neighborhoods to locate in these areas. Create a better pedestrian environment.

OBJECTIVES

Objective 1. Improve the Foster Road business district by creating a “Main Street” with a strong pedestrian orientation. Balance the needs of pedestrians for safe access to businesses with the provision of parking for those that arrive by auto.

Objective 2. Improve the portion of 82nd Avenue commercial strip in Foster-Powell.

F. Mt. Scott-Arleta Neighborhood Plan

POLICIES

Policy 2. Housing and Livability

Improve Mt. Scott-Arleta's supply of housing by protecting the existing homes and encouraging the construction of a variety of attached housing types on infill lots. New housing should blend into the neighborhood and meet the needs of residents of various ages, income levels, and backgrounds.

Policy 4. Economic Development

Improve commercial viability for business districts in the neighborhood, to provide a full range of goods and convenient neighborhood services.

Objective 1. Encourage commercial infill in areas along SE 82nd where there are vacant sites, deteriorating buildings, or under-utilized business properties.

Objective 7. Encourage storefront businesses that cater to the pedestrian along Foster Road and 72nd Avenue between SE Woodstock and Foster Road.

Policy 5. Transportation

Ensure that transit and traffic move safely and smoothly within the Mt. Scott-Arleta Neighborhood. Improve transportation facilities to encourage pedestrian and bicycle use, as well as to accommodate physically challenged persons.

G. Powellhurst-Gilbert Neighborhood Plan

POLICIES

Policy 1. Transportation

Ensure that the neighborhood is accessible by a variety of transportation modes including walking, bicycling, public transit, auto, and truck, while reducing noise, pollution and safety hazards.

Policy 2. Trails, Parks, Open Space and Environment

Ensure that the parks, green spaces, open spaces and other recreational and cultural opportunities of the Powellhurst-Gilbert neighborhood meet the needs of area residents and improve the neighborhood's appearance.

Policy 4. Housing and Neighborhood Livability

Improve the neighborhood and encourage and allow for diversity in the type and density of housing within the neighborhood.

Policy 6. Economic Development

Improve, support and create businesses that enhance the neighborhood and provide needed goods and services to residents.

H. Brentwood-Darlington Neighborhood Plan

POLICIES

Policy 4. Housing

Preserve and improve existing housing while providing opportunities for new housing for people of all ages and income levels.

Policy 6. Business and Industry

Support the retention and expansion of existing businesses and encourage new commercial uses when compatible with the surrounding neighborhood.

I. Creston Kenilworth Neighborhood Plan

POLICIES

Policy 1B. Traffic and Transportation

Support transportation improvements that enhance the appearance and livability of SE Powell Boulevard, SE Foster Road and SE Thirty-ninth Avenue.

Policy 3. Business and Economic Development

Support local businesses that serve the resident's needs, provide a public forum for interaction, and bring diversity to the neighborhood.

Policy 5B. Housing

Encourage infill housing development along transit streets and at the commercial and mixed-use nodes.

V. URBAN RENEWAL AREA

This section identifies Expansion Areas that will be added to the Area. The following exhibits are references for each of the areas:

- Exhibit I. Expansion Areas
- Exhibit II. Deletion Areas

The legal descriptions and maps identifying information about the Area are shown below. The existing exhibits are hereby replaced in their entirety to reflect the addition of the Expansion Areas to the Area:

- Exhibit A. Lents Town Center Urban Renewal Area Legal Description of Area Boundary
- Exhibit A.1 Map of Legal Description
- Exhibit B. Comprehensive Plan Map

The language contained below is added to the end of the corresponding section in the existing Plan.

B. The specific Expansion Areas are:

1. SE Foster Road Expansion Area

SE Foster Road from SE 50th Avenue to SE 79th Avenue serves as a gateway to the Lents Town Center Area. It presently has a number of small businesses which could benefit from business loan assistance. There are also parcels which are undeveloped or underdeveloped. In addition to the commercial properties, there are three multi-family residential zoned properties which are in need of rehabilitation. Upgrading of this entrance to the Area will provide a more positive and attractive entrance to the Lents Town Center as a whole and the expected spin off benefit is private investment in the Town Center Area.

2. Marysville School Expansion Area

The City has begun to develop partnerships with local schools to increase enrollment and stability in the neighborhood. Inclusion of these schools into the Area will provide the opportunity for these sites to qualify for funding for future facility improvements identified as part of this initiative. Marysville School, located at 7733 SE Raymond, is part of Portland Public Schools and serves the Lents neighborhood. Also included in this area are a number of residential parcels which may qualify for assistance through the neighborhood based housing programs.

3. SE Powell Boulevard Expansion Area

The sites west of SE 102nd Avenue on SE Powell Boulevard are potential sites for job creation. One is zoned General Industrial 2, while the other is zoned General Employment 2.

4. SE 122nd Avenue and Powell Boulevard Expansion Area

The parcels on SE 122nd Avenue are commercial and/or residential opportunity node at SE Powell Boulevard. This node will provide opportunity for the creation of new service related development for adjacent residential areas.

5. SE 122nd Avenue and Holgate Expansion Area

The parcels on SE 122nd at Holgate are a residential and commercial opportunity node. The commercial node will provide the opportunity for the creation of new service related development for adjacent residential areas. The residential area will provide the opportunity to upgrade existing housing stock.

6. Alice Ott Middle School Expansion Area

The City has begun to develop partnerships with local schools to increase enrollment and stability in the neighborhood. Inclusion of these schools into the URA will provide the opportunity for these sites to qualify for funding for future facility improvements identified as part of this initiative. This area also includes a residential development opportunity site. Alice Ott Middle School, located in this expansion area at 12500 SE Ramona Street, is part of the David Douglas School District.

7. SE 122nd Avenue and Foster Road Expansion Area

The parcels on SE 122nd Avenue at Foster Road are a commercial and/or residential opportunity node. This node will provide an opportunity for the creation of new service related development for adjacent residential areas.

8. Leach Botanical Garden Expansion Area

The Leach Botanical Garden (Garden) is a recreational, ecological, and tourism asset to the Lents Town Center Area. It brings in visitors from around the state while serving as a local park for the Lents residents. The Garden is in need of upgraded facilities to maintain its stature as a destination park. Inclusion of this site in the Area will provide the opportunity for the Garden to qualify for funding for future facility improvements and implement a new master plan.

9. Knapp Street Triangle Expansion Area

This area, located south of SE Knapp Street from SE 92nd Avenue to SE 102nd Avenue, is a prime location for future residential development. The development of additional housing will further stabilize the neighborhood and provide support to existing businesses. Its proximity to the Freeway Lands site provides an additional advantage in relation to future development of that site.

C. The specific deletions to the area are:

10. *Deletions from I-205 right of way*

Approximately 65 acres of I-205 right of way will be deleted from the Area, see Exhibit III.

VI. PROPOSED LAND USES

No changes.

VII. URBAN RENEWAL PROJECTS

The language in this section VII replaces the language in the corresponding section VII in the existing Plan in its entirety.

In order to achieve the objectives of this Plan, the following projects will be undertaken by the Commission in accordance with applicable federal, state, county and city laws, policies and procedures. These projects may be modified, expanded or eliminated as needed to meet the objectives of the Plan, subject to Section XII, Amendments to the Plan.

A. Public Improvements

Public improvements include the construction, reconstruction, repair or replacement of sidewalks, streets, transit systems, parking, parks, pedestrian amenities, water, sanitary sewer facilities, storm sewer facilities and other public infrastructure deemed appropriate for the achievement of the goals and objectives of this Plan.

1. SE Foster Road Street Improvements

SE Foster Road is the main east-west street of the Area, cutting through the heart of the Lents Town Center and serving a variety of transit, commercial and neighborhood purposes. Portions of SE Foster Road are classified by the City of Portland as a Major City Traffic Street, Major City Transit Street, City Bikeway, City Walkway and Major Truck Street. Portions of SE Foster Road are classified by Metro as a Main Street and Corridor.

It is a primary objective of this Plan that SE Foster Road plays a significant and supportive role in revitalizing the Area's commercial and neighborhood districts.

Improvements to SE Foster Road will more closely link the functions of SE Foster Road to the immediately adjacent commercial and neighborhood districts of the Area, as well as meet the objectives of the Transportation Element of the City of Portland Comprehensive Plan. These projects are also intended to support and stimulate the revitalization and redevelopment of currently vacant, underutilized or blighted commercial property in the Area by improving the utility and character of SE Foster Road in ways that the community envisions and will encourage and support redevelopment of the downtown Lents central business district.

- a) Intersection Improvements: signals, pedestrian accommodations and curb extensions.

- b) Pedestrian Improvements: safety, traffic calming, signal improvements, crossing improvements. Bicycle improvements: lane striping, signage.
- c) Bicycle improvements: signal improvements, lane striping, and signage.
- d) Assist with implementation of the Foster Road Transportation and Streetscape Plan (2003).

2. SE 82nd Avenue Improvements

SE 82nd Avenue is the main north-south traffic corridor in the Area and serves a variety of transit, commercial and neighborhood purposes. Portions of SE 82nd Avenue are classified by the City of Portland as a Major City Traffic Street, Major City Transit Street, City Walkway and Major Truck Street. Portions of SE 82nd Avenue are classified by Metro as a main street and corridor.

Improvements to this street at major intersections are intended to promote safer and more efficient circulation of vehicles and pedestrians, and encourage redevelopment of underutilized commercial property. Sidewalk and other pedestrian accommodating improvements between intersections will facilitate access of neighborhood residents to and between commercial areas.

- a) Intersection Improvements: signals, pedestrian accommodations and curb extensions.
- b) Pedestrian Improvements: traffic calming, signal improvements, crossing improvements, and sidewalks.

3. SE 92nd Avenue Improvements

SE 92nd Avenue between SE Powell Boulevard and SE Holgate Boulevard is a heavily traveled, mainly residential street impacted by cut-through commercial and freeway traffic. The street lacks sidewalks, curbs, gutters and improved intersections. These conditions contribute to the blighted appearance of this stretch of the neighborhood, as well as higher speed traffic flows which create conflicts and difficulties for pedestrian and bicycle traffic, therefore impeding the regional and local policy goals and objective of the town center.

Portions of SE 92nd Avenue are classified by the City of Portland as Neighborhood Collector Street, Minor City Transit Street, City Walkway and City Bikeway. Portions of SE 92nd Avenue are classified by Metro as a main street in the Lents Town Center area.

- a) Street Improvements: road surface, storm water control, street lights, street trees, curbs and curb extensions.

b) Pedestrian Improvements: traffic calming, signal improvements, crossing improvements, and sidewalks.

c) Bicycle Improvements: signal improvements, lane striping, and signage.

4. SE 122nd Avenue Improvements

SE 122nd Avenue, between SE Powell Boulevard and SE Foster Road, is classified by Metro as a main street and corridor, and by the City of Portland as a City Walkway, City Bikeway, Transit Access Street, Major City Traffic Street, Regional Corridor (Design). The City has designated this as a high density corridor with key commercial nodes to serve local residents.

a) Intersection Improvements: signals, pedestrian accommodations, and curb extensions.

b) Pedestrian Improvements: traffic calming, signal improvements, crossing improvements, and sidewalks.

c) Bicycle Improvements: signal improvements, lane striping, and signage.

5. SE 104th Avenue Improvements

SE 104th Avenue between SE Powell Boulevard and SE Harold Street is a local street needing significant improvements to bring it up to current standards. The community desires new sidewalks and improved conditions for bicycle and vehicular traffic. Major reconstruction of the roadbed is required to build sidewalks and facilitate proper storm water management and drainage.

a) Intersection Improvements: signals, pedestrian accommodations, and curb extensions.

b) Pedestrian Improvements: traffic calming, signal improvements, crossing improvements, and sidewalks.

c) Bicycle Improvements: signal improvements, lane striping, and signage.

d) Stormwater management and drainage.

6. Area-Wide Street Improvements — Annual Program

In order to stimulate and support desired commercial and neighborhood revitalization, funds will be available on an annual basis to respond to needs of emerging redevelopment projects and neighborhood improvement projects to

address traffic calming, pedestrian and bicycle accommodation and rebuild unimproved streets.

- a) Street Improvements: road surface, storm water control, lights, trees, curbs, and curb extensions.
- b) Pedestrian Improvements: traffic calming, signal improvements, crossing improvement, and sidewalks.

7. Parking Facilities

Redevelopment of the downtown Lents business district is a high priority of the community. The availability of adequate parking to support desired commercial activity is seen as a key ingredient in the commercial development strategy of this area. To stimulate and support the desired character and potential redevelopment of the business district, funds will be used to develop strategic parking lots or structures as defined by planning activities.

8. Public Facilities / Spaces

The development of public facilities and spaces is a key element in the development of a revitalized and healthy Lents Town Center that is attractive to future private investment and supportive of a stable neighborhood and residential character. Facilities are planned to integrate resident and public uses with commercial and economic development activities while maximizing the utility of existing and planned public infrastructure.

- a) Community / Public Service Center: to be further defined and sited as a result of a community planning process. This facility is envisioned to serve as a community-gathering place. Associated with such a facility will be other public or community uses (e.g. fire, police, fraternal organizations, youth services, school programs, library, and public offices) that create an active and multi-purpose focus for the town center.
- b) Workforce Training Center: to be further defined and sited as a result of a community planning process. This facility will serve as the focal point for coordinating and providing training of the area workforce to meet the needs of employers attracted to the area as a result of other activities of this plan.
- c) Public Square / Plaza: to be further defined and sited as a result of a community planning process. The community-desired character of the downtown Lents business district (the heart of the Lents Town Center) includes providing for a dedicated public open space which will serve as a gathering and/or market place for commercial and neighborhood activities (e.g. festivals, farmer's market, concerts). Such a place is intended to support and enhance the emerging development of the downtown Lents

business district, and encourage the integration of commercial activities with the surrounding residential neighborhood.

d) Area Gateway Projects: to be further defined and sited as a result of a community planning process. Attractive signage and/or other distinctive features will be constructed at strategic locations to identify the area and different neighborhoods.

e) School Infrastructure Improvements: to be further defined and sited following school facility assessments. Facility and infrastructure improvements may address deteriorating or inadequate facilities such as playgrounds and access, as they impact neighborhood livability.

f) Public Building Improvements: Multnomah County owns and operates the Wikman Building, which was originally built as a Carnegie Library in 1919. This facility is located within the Foster Corridor expansion area. This building is currently used for Juvenile Services - Community Based Supervision Program. The building requires substantial improvements to help meet current building codes and extend the useful life of the building. Exterior improvements will address the blighted appearance as well. The public building will serve the Area by providing public facilities and services for Area residents.

9. Watershed / Floodwater Management Projects

The impact of Johnson Creek on past and future development of the Area can not be understated. As a major water feature and natural resource, the creek has significant potential to attract development to the Area. With a history and certain future of seasonal flooding in the Area, however, future development in the watershed will need to be carefully managed to minimize their impacts on the flooding of Johnson Creek. Conversely, floodwater management projects can serve to reduce the impacts of flooding on the surrounding area and existing development. Specific projects and programs will be further defined and sited as a result of a community planning process.

a) Floodwater Management Projects: to be further defined and sited as a result of a community planning process. Projects will serve to minimize and mitigate damage from natural hazard to public and private property in the area, and downstream, through the management of floodwater during flooding events.

b) Watershed Stormwater Diversion Program: to encourage the control and on-site management of stormwater in existing and new development within the area.

10. Parks and Recreation

Parks provide recreational, natural and cultural resources for the community. By upgrading facilities, improving accessibility and adding features to area parks, these resources will better serve the surrounding community and help attract future investment.

- a) Facilities Upgrades: projects will be undertaken to improve accessibility, add new site furnishings, interpretative features and enhance other amenities at Area parks.

B. Rehabilitation, Development and Redevelopment Assistance

The Commission will undertake loans and grant programs to assist property owners and tenants in rehabilitating or redeveloping property within the Area to achieve the objectives of the Plan. This may include residential, commercial or industrial loans or grants, financial assistance to improve older buildings to meet current code standards (including seismic standards), assistance to remediate environmental conditions, or other programs to eliminate blight in the area.

The Commission, with funds available to it, is authorized to establish financial assistance programs and provide below-market rate interest and market rate interest loans and provide such other forms of financial assistance to property owners, owners of buildings, tenants, community groups, non-profits which are in need of rehabilitation or persons desiring to acquire or lease property from the Commission, as it may deem appropriate in order to achieve the objectives of the Plan.

The Commission may acquire, improve and dispose of property that presents an opportunity to implement major private redevelopment projects, in conformance with the Comprehensive Plan, Zoning Ordinance and goals and objectives of this Plan. The detailed provisions pertaining to these activities are described in Sections VIII and IX of this Plan.

The Commission may undertake planning projects related to achieving the goals and objectives of this Plan.

1. Economic / Commercial Development

The Commission will support a variety of programs designed to maximize the development potential of underutilized property, employment potential of existing businesses, and improve the vitality and economic health of commercial and industrial areas to attract private development and employment activities.

- a) Business Finance: Financial assistance through loans or grants to help businesses grow and create jobs. Tax increment funds may be leveraged with private or other public funds.

- b) **Storefront Improvement:** Provide financial assistance to property owners or tenants to improve the appearance of commercial storefront properties.
- c) **Business Retention:** Provides technical assistance for businesses to improve productivity, competitiveness and resource conservation.
- d) **Target Industry Development:** Planning and implementation of strategies to increase quality, family wage jobs in the Area.
- e) **Community Economic Development:** Financial and technical assistance and other incentive programs to support commercial corridor revitalization, development of catalytic commercial projects, historical preservation and other opportunities to increase economic activity.

2. Housing Development

The Commission will support a variety of projects and programs, which will provide new and rehabilitated housing for residents and workers in the Area. Neighborhood revitalization and residential stabilization will have an important influence on the retention, attraction and expansion of commercial and employment opportunities in the Area.

- a) **Homeowner Repair Program:** Provide financial assistance to homeowners for the purpose of making repairs and improvements to their house and property.
- b) **Homebuyer Program:** Provide financial assistance to Area residents and employees in purchasing a house in the area.
- c) **Housing New Development and Revitalization/ Rehabilitation (Rental and Ownership) Program:** Provide technical and/or financial assistance to developers of new rental and ownership housing, and property owners making improvements to existing affordable housing stock, according to City and Commission housing policies and plans. This may include development of new affordable senior, workforce or family housing, repair/rehabilitation and preservation of existing low-income rental properties, and development of affordable rental and/or ownership housing as part of mixed-use projects that meet other revitalization goals (Section 3, below) in the Area to further the goals and objectives of this Plan.
- d) **Housing Replacement:** Facilitate the construction of up to 78 housing units by the year 2017 or prior to the completion of this Plan, whichever occurs first, as replacement for housing opportunity lost through rezoning of approximately 77,200 square feet of property from residential to commercial in the downtown Lents business district. This replacement shall be accomplished within the Area in one of the following ways:

1. Building 39 housing units on land without zoning requiring the construction of housing (e.g. commercial, commercial storefront [CS] or central employment [EX] zones). Units replaced by this method shall be calculated at 1 unit / 2,000 SF of site area.
2. Increase the housing potential within the Plan Area by 78 housing units (Units replaced by this method shall be calculated at 1 unit / 1,000 SF of site area) by:
 - a) Securing approval for comprehensive plan map amendments and zone changes of non-residential zoning to residential zoning; or
 - b) Increasing the allowed densities on residentially zoned land.
3. A combination of methods #1 or #2 above where proportionate housing replacement is obtained and densities are calculated:
 - a) For method #1: 1 housing unit per 2,000 SF of site area.
 - b) For method #2: 1 housing unit per 1,000 SF of site area.

3. Commercial Redevelopment and Revitalization

The Commission will undertake redevelopment projects and financial assistance programs to support neighborhood revitalization, encourage development of underutilized properties for a variety of uses, including mixed-use commercial and residential, that will generate employment and housing opportunities and increase access to neighborhood and commercial services. Assistance includes predevelopment activities, acquisition, improvement, and disposition of real estate, financial and loan programs, access and infrastructure, and technical expertise.

- a) Lents Town Center Revitalization: Provide assistance to support development of the business district in accordance with the goals and objectives of the Plan.
- b) Station Area Redevelopment: Facilitate and assist integration of transit oriented development around Green Line MAX light rail stations at SE Powell Boulevard, SE Holgate Boulevard and SE Flavel Street.

c) Commercial Corridor Revitalization: Target assistance for commercial property redevelopment, retail retention and improvements, and redevelopment opportunities at key sites including SE 92nd Avenue, SE Foster Road and SE Woodstock Boulevard in Town Center business district, SE Foster Road between SE 50th and SE 82nd Avenues and SE 122nd Avenue commercial nodes.

4. Johnson Creek Industrial Area Revitalization

The Commission will undertake redevelopment projects and financial assistance programs to support industrial area revitalization and encourage development of underutilized properties that will generate employment. Assistance includes predevelopment activities, acquisition, improvement, and disposition of real estate, financial and loan programs, technical expertise, and access and infrastructure assistance.

Financial Assistance: Provide assistance for improvements to support employment generating development.

Access and Infrastructure Assistance: Provide technical expertise and/or financial assistance to integrate access and infrastructure, including watershed/flood management planning, that improve existing and future economic uses in the Johnson Creek Industrial Area and connectivity to the new MAX Green Line light rail transit stations.

C. Administration

The Commission will undertake administration of all aspects of the Plan including staffing, materials and services, and overhead.

VIII. PROPERTY ACQUISITION AND DISPOSITION

No change.

IX. PROPERTY DISPOSITION POLICIES AND PROCEDURES

No change.

X. RELOCATION POLICIES AND PROCEDURES

No change.

XI. TAX INCREMENT FINANCING

The language in this section XI replaces the language in the corresponding section XI in the existing Plan in its entirety.

C. Maximum Indebtedness

1. The maximum indebtedness that may be issued or incurred under the plan is TWO HUNDRED, FORTY-FIVE MILLION DOLLARS (\$245,000,000).
2. Any indebtedness permitted by law and incurred by the Commission or the City of Portland in connection with the preparation of this Plan or prior planning efforts related to this Plan may be repaid from tax increment revenues from the Area when and if such funds are available.
3. No additional indebtedness would be incurred under the Plan when either (1) the maximum indebtedness amount is reached, (2) the urban renewal area no longer has indebtedness or any plan to incur indebtedness within the next year or (3) on June 30, 2020, whichever comes first.

XII. AMENDMENTS TO PLAN

This section XII replaces the section XII in the existing Plan in its entirety.

This Plan may be reviewed and evaluated periodically, and may be amended as needed, in conformance with statutory requirements. All amendments to this Plan shall be made pursuant to the following procedures.

A. Substantial Amendments

Substantial amendments are solely amendments:

1. Adding land to the urban renewal area, except for an addition of land that totals not more than one percent of the existing area of the urban renewal area.
2. Increasing the maximum amount of indebtedness that can be issued or incurred under the plan.

Substantial amendments shall require the same approval process as required for initial plan adoption including the approval process as provided in ORS 457.095 and the notice requirement set forth in ORS 457.120.

B. Major Amendments

A major amendment is solely an amendment:

1. Adding land to the urban renewal area that totals not more than one percent of the existing area of the urban renewal area.

Major amendments shall be forwarded to the Planning Commission for recommendations as described in ORS 457.085(4) and shall require City Council approval as provided in ORS 457.095, but shall not require the notice described in ORS 457.120 or compliance with the procedures described in ORS 457.085(5). A report as required by ORS 456.085(3) shall accompany the amendment.

C. Council-Approved Amendments

Council-approved amendments are solely amendments:

1. Changing the Goals of the Plan.
2. Removing land from the urban renewal area.
3. Extending the last date to issue debt.
4. Identifying a building in a project as a public building and explaining how the building serves or benefits the urban renewal area.

Council-approved amendments require approval by the Portland Development Commission by resolution and by the City Council, which may approve the amendment by resolution. Council-approved amendments do not require any of the procedural or notice requirements found in ORS Chapter 457, including but limited to the procedures set forth in ORS 457.085 (4) and (5).

D. Minor Amendments

Minor amendments are amendments that are neither substantial, major, nor council-approved amendments. Minor amendments are effective upon adoption of a resolution by the Portland Development Commission approving the amendment.



EXHIBIT A

Lents Town Center Urban Renewal Area

Legal Description of Area Boundary

(Document Numbers and Book and Page records are per Multnomah County Deed Records. "SN" numbers are the recording numbers for records of survey on file at Multnomah County Surveyors Office).

Commencing in the southeast one-quarter of the northeast one-quarter of Section 8, Township 1 South, Range 2 East of the Willamette Meridian, City of Portland, County of Multnomah, State of Oregon at the intersection of the north right-of-way line of S.E. Powell Boulevard with the northerly prolongation of the west right-of-way line of S.E. 79th Avenue for the POINT OF BEGINNING of the Lents Town Center Urban Renewal Boundary Line, Assessor Map 1S 2E 8AD;

1. Thence easterly along said north right-of-way line of S.E. Powell Boulevard to the west right-of-way line of S.E. 79th Avenue, Assessor Map 1S 2E 8AD;
2. Thence northerly along the west right-of-way line of S.E. 79th Avenue to the westerly prolongation of the south line of the plat of "Dunton", Assessor Map 1S 2E 8AD;
3. Thence easterly along the south line of the plat of "Dunton" and it's westerly and easterly prolongation to the east right-of-way line of S.E. 82nd Avenue, said Assessor Map 1S 2E 8AD;
4. Thence southerly along the east right-of-way line of S.E. 82nd Avenue to the north right-of-way line of S.E. Franklin Street, Assessor Map 1S 2E 9BC;
5. Thence easterly along the north right-of-way line of S.E. Franklin Street to the northerly prolongation of the east line of that tract of land described in Document No. 2007-142835, recorded August 8, 2007 (Tax Lot 12600), Assessor Map 1S 2E 9BC;
6. Thence southerly along the east line of that tract of land described in Document No. 2007-142835, recorded August 8, 2007 (Tax Lot 12600) and it's northerly prolongation to the southeast corner thereof, Assessor Map 1S 2E 9BC;

Sheet 1 of 49



7. Thence easterly along the north lines of those tracts of land described in Document No. 2002-210755, recorded November 19, 2002 (Tax Lot 12400); Document No. 2000-053497, recorded April 18, 2000 (Tax Lot 12300); Document No. 96-188089, recorded December 16, 1996 (Tax Lot 12200); and Document No. 94-168808, recorded November 15, 1994 (Tax Lot 12100) to the northeast corner of said Document No. 94-168808 tract (Tax Lot 12100), Assessor Map 1S 2E 9BC;
8. Thence southerly along the east line of that tract of land described in Document No. 94-168808, recorded November 15, 1994 (Tax Lot 12100) to the southwest corner of that tract of land described in Document No. 2007-175330, recorded October 3, 2007 (Tax Lot 11800), Assessor Map 1S 2E 9BC;
9. Thence easterly along the south line of that tract of land described in Document No. 2007-175330, recorded October 3, 2007 (Tax Lot 11800) to the southeast corner thereof, said southeast corner being on the west right-of-way line of S.E. 84th Avenue, Assessor Map 1S 2E 9BC;
10. Thence northerly along the east line of that tract of land described in Document No. 2007-175330, recorded October 3, 2007 (Tax Lot 11800), which is also the west right-of-way line of S.E. 84th Avenue to the westerly prolongation of the north line of that tract of land described in Book 2141, Page 1060, recorded September 26, 1988 (Tax Lot 10200), Assessor Map 1S 2E 9BC;
11. Thence easterly along the north line of those tracts of land conveyed in Book 2140, Page 1060, recorded September 26, 1988 (Tax Lot 10200); Book 1956, Page 1414, recorded November 18, 1986 (Tax Lot 10100); and Document No. 96-139717, recorded September 13, 1996 (Tax Lot 9900), and their westerly and easterly prolongation to the west right-of-way line of S.E. 85th Avenue as originally shown in the plat of "Johnston Acres", Assessor Map 1S 2E 9BC;
12. Thence northerly along the west right-of-way line of S.E. 85th Avenue as shown on the plat of "Johnston Acres" to the westerly prolongation of the north line of Lot 17, Block 5 of the plat of "Johnston Acres", Assessor Map 1S 2E 9BC;
13. Thence easterly along the north line of Lot 17, Block 5 of the plat of "Johnston Acres" and it's westerly prolongation to the northeast corner thereof, Assessor Map 1S 2E 9BC;



14. Thence southerly along the east line of Lot 17, Block 5 of the plat of "Johnston Acres" to the southeast corner thereof, which is also the southwest corner of Lot 10, Block 5 of said plat, Assessor Map 1S 2E 9 BC;
15. Thence easterly along the south line of Lot 10, Block 5 of the plat of "Johnston Acres" to the southeast corner thereof, said southeast corner being on the west right-of-way line of S.E. 87th Avenue, Assessor Map 1S 2E 9BC;
16. Thence easterly to the southwest corner of Lot 17, Block 6 of the plat of "Johnston Acres", said southeast corner being on the east right-of-way line of S.E. 87th Avenue, Assessor Map 1S 2E 9BC and Assessor Map 1S 2E 9BD;
17. Thence easterly along the south line of Lot 17, Block 6 of the plat of "Johnston Acres" to the southeast corner thereof, Assessor Map 1S 2E 9BD;
18. Thence northerly along the east line of Lot 17, Block 6 of the plat of "Johnston Acres" to the northeast corner thereof, which is also the northwest corner of Lot 10, Block 6 of said plat, Assessor Map 1S 2E 9BD;
19. Thence easterly along the north line of Lot 10, Block 6 of the plat of "Johnston Acres" to the northeast corner of that tract of land described in Document 2006-165528, recorded September 5, 2006 (Tax Lot 6800), Assessor Map 1S 2E 9BD;
20. Thence southerly along the east line of that tract of land described in Document 2006-165528, recorded September 5, 2006 (Tax Lot 6800) to the south line of Lot 10, Block 6 of the plat of "Johnston Acres", Assessor Map 1S 2E 9BD;
21. Thence easterly along the south line of Lot 10, Block 6 of the plat of "Johnston Acres" to a point on the west right-of-way line of S.E. 89th Avenue, Assessor Map 1S 2E 9BD;
22. Thence northerly along said west right-of-way line of S.E. 89th Avenue to the westerly prolongation of the north property line of that tract of land described in Document No. 2003-302511, recorded December 30, 2003 (Tax Lot 4300), Assessor Map 1S 2E 9BD;
23. Thence easterly along the north line of those tracts of land described in Document No. 2003-302511, recorded December 30, 2003 (Tax Lot 4300) and Document No. 2004-236590, recorded December 30, 2004 (Tax Lot 4100 and

- Tax Lot 4200) and the westerly prolongation of said north line to a point on the west right-of-way line of S.E. 90th Place, Assessor Map 1S 2E 9BD;
24. Thence northerly along the west right-of-way line of S.E. 90th Place to the westerly prolongation of the south line of that tract described in Document No. 2006-233644, recorded December 19, 2006 (Tax Lot 1500), Assessor Map 1S 2E 9BD;
 25. Thence easterly along the south line of those tracts of land described in Document No. 2006-233644, recorded December 19, 2006 (Tax Lot 1500) and Document No. 2006-233645, recorded December 19, 2006 (Tax Lot 1700), and the westerly prolongation to the east line of Lot 57 of the plat of "Plympton Acres", Assessor Map 1S 2E 9BD;
 26. Thence northerly along east line of Lot 57 of the plat of "Plympton Acres" to the northwest corner of that tract of land described in Document No. 2002-127237, recorded July 18, 2002 (Tax Lot 700), Assessor Map 1S 2E 9BD;
 27. Thence easterly along the north line of that tract of land described in Document No. 2002-127237, recorded July 18, 2002 (Tax Lot 700) to the west right-of-way line of S.E. 92nd Avenue, Assessor Map 1S 2E 9BD;
 28. Thence easterly to the southwest corner of that tract of land described in Document No. 2001-154214, recorded September 28, 2001 (Tax Lot 1300), said southwest corner being on the east right-of-way line of S.E. 92nd Avenue, Assessor Map 1S 2E 9AC and Assessor Map 1S 2E 9BD;
 29. Thence easterly along the south line of that tract of land described in Document No. 2001-154214, recorded September 28, 2001 (Tax Lot 1300) to the east line Lot 53 of the plat of "Plympton Acres", said east line also being the west right-of-way line of U.S. Highway I-205, Assessor Map 1S 2E 9AC;
 30. Thence southerly along the east line of Lots 53 and 54 of the plat of "Plympton Acres", said east line also being the west right-of-way line of U.S. Highway I-205 to a point of curvature along the easterly line of that tract of land described in Document 96-188167, recorded December 16, 1996 (Tax Lot 800), Assessor Map 1S 2E 9AC;
 31. Thence southwesterly along the southeasterly line of that tract of land described in Document No. 96-188167, recorded December 16, 1996 (Tax Lot 800), which

is also the westerly right-of-way line of U.S. Highway I-205 and being along a 100.00 foot radius curve, concave northwesterly to a point on the north right-of-way line of S.E. Powell Boulevard, said right-of-way line being 40.00 feet from the centerline thereof, said Assessor Map 1S 2E 9AC;

32. Thence easterly along a line that is 40.00 feet northerly from the centerline of the right-of-way of S.E. Powell Boulevard (underpass) to a point the southeast corner of that tract of land dedicated for public right-of-way in Book 2020, Page 416, recorded July 28 1960, Assessor Map 1S 2E 9DA;
33. Thence northerly along the east line of that tract of land dedicated for public right-of-way in Book 2020, Page 416, recorded July 28, 1960 to the south right-of-way line of a public road as shown in the unrecorded plat of "Ferguson Tracts", which is recorded in Multnomah County Survey Records as SN 7212, Assessor Map 1S 2E 9DA;
34. Thence easterly along the south right-of-way line of a public road as shown in the unrecorded plat of "Ferguson Tracts", which is recorded as SN 7212, to the east line of said unrecorded plat, Assessor Map 1S 2E 9DA;
35. Thence southerly along the east line of the unrecorded plat of "Ferguson Tracts, which is recorded in Multnomah County Survey Records as SN 7212 to the north right-of-way line of S.E. Powell Boulevard, Assessor Map 1S 2E 9DA;
36. Thence easterly along the north right-of-way line of S.E. Powell Boulevard to the east line of that tract of land described in Document No. 99-159434, recorded August 20, 1999 and referred to as Parcel II therein (portion of Tax Lot 100), Assessor Map 1S 2E 9DA;
37. Thence northerly along the east line of that tract of land described in Document No. 99-159434, recorded August 20, 1999 and referred to as Parcel II therein (portion of Tax Lot 100) to the south line of that tract of land shown in SN 19378, (portion of Tax Lot 100), said south line being 210.00 feet, southerly from the east-west center of section line for Section 9, Township 1 South, Range 2 East of the Willamette Meridian, Assessor Map 1S 2E 9DA;
38. Thence easterly along said south line of that tract of land shown in SN 19378 (portion of Tax Lot 100) to a point on the east line of Section 9, which is also the west line of Section 10, all within Township 1 South, Range 2 East of the



- Willamette Meridian, said point being 210.00 feet from the one-quarter section corner on the common line between said sections, Assessor Map 1S 2E 9DA;
39. Thence northerly, 210.00 feet along the east line of Section 9, which is also the west line of Section 10, all within Township 1 South, Range 2 East of the Willamette Meridian to the one-quarter section corner on the common line between said sections, said one-quarter section corner also being the northwest corner of that tract of land described in Book 2644, Page 2638, recorded February 2, 1993 (Tax Lot 1000), Assessor Map 1S 2E 9DA and Assessor Map 1S 2E 10B;
 40. Thence easterly along the north line of that tract of land described in Book 2644, Page 2637, recorded February 2, 1993 (Tax Lot 1000) to the northeast corner thereof, Assessor Map 1S 2E 10B;
 41. Thence southerly along the east line of that tract of land described in Book 2644, Page 2637, recorded February 2, 1993 (Tax Lot 1000) to the north right-of-way line of S.E. Powell Boulevard, Assessor Map 1S 2E 10B;
 42. Thence easterly along the north right-of-way line of S.E. Powell Boulevard to the west line of that tract of land described in Document No. 2003-291801, recorded December 12, 2003 (Tax Lot 1100), Assessor Map 1S 2E 10B;
 43. Thence northerly along the west line of that tract of land described in Document No. 2003-291801, recorded December 12, 2003 (Tax Lot 1100) to the northwest corner thereof, Assessor Map 1S 2E 10B;
 44. Thence easterly along the north line of that tract of land described in Document No. 2003-291801, recorded December 12, 2003 (Tax Lot 1100) to the northeast corner thereof, Assessor Map 1S 2E 10B;
 45. Thence southerly along the courses of the east line of that tract of land described in Document No. 2003-291801, recorded December 12, 2003 (Tax Lot 1100) to the north right-of-way line of S.E. Powell Boulevard, Assessor Map 1S 2E 10B;
 46. Thence easterly along the north right-of-way line of S.E. Powell Boulevard to the east right-of-way line of S.E. 122nd Avenue, Assessor Map 1S 2E 10B, Assessor Map 1S 2E 10AC, and Assessor Map 1S 2E 10AD;

47. Thence northerly along said east right-of-way line of S.E. 122nd Avenue to the northwest corner of that property per Document No. 2001-030413, recorded March 6, 2001 (Tax Lot 10600), Assessor Map 1S 2E 11BC;
48. Thence easterly along the north line of said property per Document No. 2001-030413 (Tax Lot 10600) and the north line of that property per Document No. 2006-189497, recorded October 12, 2006 (Tax Lot 10601) to the northeast corner thereof, Assessor Map 1S 2E 11BC;
49. Thence southerly along the east line of those properties per Document No. 2006-189497 (Tax Lot 10601), Document No. 2002-135759, recorded July 31, 2002 (Tax Lot 10700), and Document No. 2002-097971, recorded May 31, 2002 (Tax Lot 10800) to a point on the north line of that property per Document No. 2007-150068, recorded August 20, 2007 (Tax Lot 10900), Assessor Map 1S 2E 11BC;
50. Thence easterly along said north line of that property per Document No. 2007-150068 (Tax Lot 9900 and Tax Lot 10900) to a point on the west right-of-way line of S.E. 124th Avenue, Assessor Map 1S 2E 11BC;
51. Thence northerly along said west right-of-way line of S.E. 124th Avenue to a point on the south line of that property per Document No. 2007-178247, recorded October 9, 2007 (Tax Lot 6100), Assessor Map 1S 2E 11BC;
52. Thence easterly along said south property line, the north right-of-way line of said S.E.124th Avenue, and the north property line of those properties per Document No. 2001-061823, recorded April 30, 2001 (Tax Lot 9200) and Document No. 98-234350, recorded December 23, 1998 (Tax Lot 9100) to a point on the west property line of that property per Book 2078, Page 1713, recorded February 9, 1988 (Tax Lot 8900), Assessor Map 1S 2E 11BC;
53. Thence northerly along the west property line of said Book 2078, Page 1713 (Tax Lot 8900) to the northwest corner thereof, Assessor Map 1S 2E 11BC;
54. Thence easterly along the north property line of said property per Book 2078 Page 1713 (Tax Lot 8900), the north property line of that property per Document No. 2007-163936, recorded September 13, 2007 (Tax Lot 8600), and the north right-of-way line of S.E. 127th Place to a point on the east right-of-way line thereof, Assessor Map 1S 2E 11BC;

55. Thence southerly along the east right-of-way line of S.E. 127th Place and it's southerly prolongation to the south right-of-way line of S.E. Powell Boulevard, Assessor Map 1S 2E 11BC;
56. Thence westerly along said south right-of-way line of S.E. Powell Boulevard to the northeast corner of that tract of land dedicated for public right-of-way in Book 674, Page 1515, recorded April 30, 1969, Assessor Map 1S 2E 11CB;
57. Thence southerly along the east right-of-way line of that tract of land dedicated for public use in Book 674, Page 1515, recorded April 30, 1969 to the southerly termination of this right-of-way, Assessor Map 1S 2E 11CB;
58. Thence westerly along the southerly termination of the right-of-way dedicated for public use in Book 674, Page 1515, recorded April 30, 1969 to a point on the east property line of that property per Document No. 2006-165464, recorded September 5, 2006 (Tax Lot 400), Assessor Map 1S 2E 11CB;
59. Thence southerly along said east property line of said property per Document No. 2006-165464 (Tax Lot 400) to the southeast corner thereof, Assessor Map 1S 2E 11CB;
60. Thence westerly along the south property line of said property per Document No. 2006-165464 (Tax Lot 400), and those properties per Book 2560 Page 774, recorded May 12, 2004 (Tax Lot 500); Document No. 2007-190715, recorded October 31, 2007 (Tax Lot 600), and Document No. 2006-068863, recorded April 17, 2006 (Tax Lot 700) to the east line of Parcel 1 of Partition Plat No. 2002-057, Assessor Map 1S 2E 11CB;
61. Thence northerly along the east of Parcel 1 of Partition Plat No. 2002-057 to the northeast corner thereof, Assessor Map 1S 2E 11CB;
62. Thence westerly along the north line of Parcel 1 of Partition Plat No. 2002-057 to the northwest corner thereof, said northeast corner being a point on the easterly termination of the right-of-way of S.E. Powell Court, Assessor Map 1S 2E 11CB;
63. Thence southerly along the west line of Parcel 1 of Partition Plat No. 2002-057, which is also along the easterly termination of the right-of-way of S.E. Powell Court to the south right-of-way line of S.E. Powell Court, Assessor Map 1S 2E 11CB;

64. Thence westerly along the south right-of-way line of S.E. Powell Court to the northwest corner of Lot 27, Block A of the plat of "Suburban Homes Club Tract", Assessor Map 1S 2E 11CB;
65. Thence southerly along the west line of Lot 27, Block A of the plat of "Suburban Homes Club Tract" to the most easterly, north line of that tract of land described in Document No. 2007-116594, recorded June 28, 2007 (Tax Lot 1000), Assessor Map 1S 2E 11CB;
66. Thence easterly along the most easterly, north line of that tract of land described in Document No. 2007-116594, recorded June 28, 2007 (Tax Lot 1000) to the west line of Parcel 1 of Partition Plat No. 2002-057", Assessor Map 1S 2E 11CB;
67. Thence southerly along the west line of Parcel 1 and Parcel 2 of Partition Plat No. 2002-057 and the west line of Lot 2 and Lot 3 of the plat of "Hessenwold" to the northeast corner of that property per Book 1969, Page 2951, recorded December 31, 1986 referred to therein as the north 150 feet of the south 311.1 feet of Lot 8, Block A of the plat of "Suburban Homes Club Tract" (Tax Lot 4100), Assessor Map 1S 2E 11CB;
68. Thence westerly along the north line of that property per Book 1969, Page 2951, recorded December 31, 1986 referred to therein as the north 150 feet of the south 311.1 feet of Lot 8, Block A of the plat of "Suburban Homes Club Tract" (Tax Lot 4100) to a point on west line of said Lot 8, Block A, Assessor Map 1S 2E 11CB;
69. Thence southerly along the west line of Lot 8, Block A of the plat of "Suburban Homes Club Tract" and the southerly prolongation to a point on the south right-of-way line of S.E. Bush Street, Assessor Map 1S 2E 11CB;
70. Thence westerly along said south right-of-way line of S.E. Bush Street to the northeast corner of that property per Document No. 2007-155434, recorded August 29, 2007 (Tax Lot 4900), Assessor Map 1S 2E 11CB;
71. Thence southerly and westerly along the east and south lines of said property per Document No. 2007-155434 (Tax Lot 4900) to a point on the east right-of-way line of S.E. 122nd Avenue, Assessor Map 1S 2E 11CB;

72. Thence southerly along the east right-of-way line of S.E. 122nd Avenue to a point on the north line of that property per Document No. 99-120043, recorded June 16, 1999 (Tax Lot 9100), Assessor Map 1S 2E 11CB and 1S 2E 11CC;
73. Thence easterly along the north line of said property per Document No. 99-120043 (Tax Lot 9100) to the northeast corner thereof, Assessor Map 1S 2E 11CC;
74. Thence southerly along the east line of said property per Document No. 99-120043 (Tax Lot 9100) to the north line of Lot 7, Block E of the plat of "Suburban Homes Club Tract", Assessor Map 1S 2E 11CC;
75. Thence easterly along the north line of Lot 7, Block E of the plat of "Suburban Homes Club Tract" to the northeast corner of that property per Document No. 2005-162933, recorded August 26, 2005 (Tax Lot 9300), Assessor Map 1S 2E 11CC;
76. Thence southerly along the east line of said property per Document No. 2005-162933 (Tax Lot 9300) and it's southerly prolongation to a point on the south right-of-way line of S.E. Holgate Boulevard, Assessor Map 1S 2E 11CC;
77. Thence westerly along the south right-of-way line of S.E. Holgate Boulevard to a point on the west line of that property per Book 2664, Page 1, recorded March 23, 1993 and referred to as Parcel I therein (Tax Lot 1600), Assessor Map 1S 2E 14BB;
78. Thence southerly along the west line of said property per Book 2664, Page 1 (Tax Lot 1600) to a point on the north line of that property per Document No. 2003-174486, recorded July 28, 2003 and referred to as Parcel I therein (portion of Tax Lot 2000), Assessor Map 1S 2E 14BB;
79. Thence westerly along the north line of said property per Document No. 2003-174486 (portion of Tax Lot 2000) to a point on the east right-of-way line of S.E. 122nd Avenue, Assessor Map 1S 2E 14BB;
80. Thence southerly along the east right-of-way line of S.E. 122nd Avenue to a point on the north line of the plat of "Herrin Court", Assessor Map 1S 2E 14BB, Assessor Map 1S 2E 14BC, and Assessor Map 1S 2E 14CB;

81. Thence northeasterly along said north plat line to the northeast corner of Lot 8, Block 1 of the plat of "Herrin Court", Assessor Map 1S 2E 14CB;
82. Thence southerly along the east line of Lot 8, Block 1 of the plat of "Herrin Court" to a point on the north right-of-way line of S.E. Ramona Street, Assessor Map 1S 2E 14CB;
83. Thence easterly along the north right-of-way line of S.E. Ramona Street to the northerly prolongation of the east line of that property per Document No. 99-214280, recorded November 24, 1999 and referred to as Parcel 3 therein (portion of Tax Lot 13800), Assessor Map 1S 2E 14CB;
84. Thence southerly along said northerly prolongation and the east line of said property per Document No. 99-214280 and referred to as Parcel 3 therein (portion of Tax Lot 13800 and a portion of Tax Lot 1600) to the north line of said property per Document No. 99-214280 and referred to as Parcel 4 therein (portion of Tax Lot 1600), Assessor Map 1S 2E 14CB and Assessor Map 1S 2E 14CC;
85. Thence easterly along the north line of said property per Document No. 99-214280 and referred to as Parcel 4 therein (portion of 1600) to the northeast corner of said Parcel 4, Assessor Map 1S 2E 14CC;
86. Thence southerly along the east line of said property per Document No. 99-214280 and referred to as Parcel 4 therein (portion of 1600) to the north line of said property per Document No. 99-214280 and referred to as Parcel 7 therein (portion of Tax Lot 1600), Assessor Map 1S 2E 14CC;
87. Thence easterly along the north line of said property per Document No. 99-214280 and referred to as Parcel 7 therein (portion of Tax Lot 1600) to the northeast corner of said Parcel 7, Assessor Map 1S 2E 14CC;
88. Thence southerly along the east line of said property per Document No. 99-214280 and referred to as Parcel 7 therein (portion of Tax Lot 1600) to the northeast corner of the plat of "Foster Park Condominium", Assessor Map 1S 2E 14CC;
89. Thence westerly along the north line of said plat of "Foster Park Condominium" and alone a line that is 300.00 feet northerly from the centerline of S.E. Foster

- Road to the northwest corner of that property per Document No. 95-98710, recorded August 17, 1995 (Tax Lot 4900), Assessor Map 1S 2E 14CC;
90. Thence southerly along the west line of said property per Document No. 95-98710 (Tax Lot 4900) to a point on the north right-of-way line of S.E. Foster Road, Assessor Map 1S 2E 14CC;
 91. Thence southerly across said right-of-way of S.E. Foster Road to the intersection of the south right-of-way line of S.E. Foster Road with the east line of Lot 1 of the plat of "Lentona", Assessor Map 1S 2E 14CC;
 92. Thence southerly along the east line of Lot 1 of the plat of "Lentona" to the southeast corner thereof, Assessor Map 1S 2E 14CC;
 93. Thence westerly along the south lines of Lots 1 through 3 of the plat of "Lentona" to a point on the east right-of-way line of S.E. 122nd Avenue, Assessor Map 1S 2E 14CC and Assessor Map 1S 2E 23BB;
 94. Thence southerly along the east right-of-way line of S.E. 122nd Avenue to the north right-of-way line of that right-of-way dedicated for public use in the plat of "Lentona", said north right-of-way line also being the south line of Lot 4 of the plat of "Lentona", Assessor Map 1S 2E 23BB;
 95. Thence southerly to the intersection of south right-of-way line of that right-of-way dedicated for public use in the plat of "Lentona" with the east right-of-way line of S.E. 122nd Avenue, Assessor Map 1S 2E 23BB;
 96. Thence easterly along said south right-of-way line, which is also the south line of the plat of "Lentona" to the easterly termination of said right-of-way at the southeast corner of said plat, Assessor Map 1S 2E 23BB;
 97. Thence northerly along the east line of the plat of "Lentona" to the northwest corner of that property per Book 1969 Page 1088, recorded December 31, 1986 (Tax Lot 1100), Assessor Map 1S 2E 23BB;
 98. Thence easterly along the north line of said property per Book 1969 Page 1088 (Tax Lot 1100) to the northwest corner of the plat of "Lydia Court", Assessor Map 1S 2E 23BB;

99. Thence southerly along the west line of the plat of "Lydia Court" to the southwest corner thereof, Assessor Map 1S 2E 23BB;
100. Thence easterly along the south line of the plat of "Lydia Court" to the west right-of-way of S.E. 128th Avenue as dedicated in Book 1510, Page, recorded March 17, 1981, Assessor Map 1S 2E 23BB;
101. Thence southerly along said west right-of-way line of S.E. 128th Avenue to a line that is 15.00 feet south of the south line of the plat of "Lydia Court", measured perpendicular thereto, said line also being a property line of that property per Document No. 99-013782, recorded January 21, 1999 (Tax Lot 400), Assessor Map 1S 2E 23BB;
102. Thence westerly, southerly, easterly, and then again southerly along the courses of property line of said property per Document No. 99-013782 (Tax Lot 400) to the southeast corner thereof, Assessor Map 1S 2E 23BB;
103. Thence westerly along the south line of said property per Document No. 99-013782 (Tax Lot 400) to a point on the east line of that property per Book 927 Page 1329, recorded May 21, 1973 (Tax Lots 800, 900, 1000, and 1900), Assessor Map 1S 2E 23BB;
104. Thence south along said east line of that property per Book 927 Page 1329 (Tax Lots 800, 900, 1000, and 1900) to a point on the north right-of-way line of S.E. 122nd Drive, Assessor Map 1S 2E 23BB;
105. Thence northwesterly along the northeasterly right-of-way line of S.E. 122nd Drive to the east right-of-way line of S.E. 122nd Avenue, Assessor Map 1S 2E 23BB;
106. Thence northerly and northwesterly along the east and northeast right-of-way lines of S.E. 122nd Avenue to the northerly prolongation of the east line of Lot 1 of the plat of "Foster Village", Assessor Map 1S 2E 23BB;
107. Thence southerly along said northerly prolongation and the east line of Lot 1 of the plat of "Foster Village" to the southeast corner thereof, said southeast corner being an angle point in the north line of that property per Book 1833, Page 2327, recorded June 28, 1985 (Tax Lot 2300), Assessor Map 1S 2E 23BB;

108. Thence southeasterly along the north line of said property per Book 1833 Page 2327 to a point on the west right-of-way line of S.E. 122nd Avenue, Assessor Map 1S 2E 23BB;
109. Thence southerly along said west right-of-way line of S.E. 122nd Avenue to an angle point in the west right-of-way line of S.E. 122nd Avenue, said angle point being at the intersection with the west right-of-way line of S.E. Brookside Drive, Assessor Map 1S 2E 23BB;
110. Thence southerly and westerly along the west and south right-of-way lines of said S.E. Brookside Drive to the southeast corner of Lot 1 of the plat of "Brookside", Assessor Map 1S 2E 23BB;
111. Thence northerly along the east line of Lot 1 of the plat of "Brookside" to the northeast corner thereof, said northeast corner being on the south line of Lot 1 of the plat of "Foster Village", Assessor Map 1S 2E 23BB;
112. Thence westerly along the south line of Lot 1 of the plat of "Foster Village" to the southwest corner of that property per Document No. 99-229260, recorded December 23, 1999 (Tax Lot 2100), Assessor Map 1S 2E 23BB;
113. Thence northerly along the west line of said property per Document No. 99-229260 (Tax Lot 2100) to the southwest right-of-way line of S.E. 122nd Avenue, Assessor Map 1S 2E 23BB;
114. Thence northerly across S.E. 122nd Avenue to the intersection of the north line of S.E. 122nd Avenue with the most easterly, south line of that property per Document No. 99-126760, recorded June 28, 1999 being that portion referred to as Parcel 3 therein (portion of Tax Lot 1700), Assessor Map 1S 2E 23BB;
115. Thence northwesterly along the north right-of-way line of S.E. 122nd Avenue to the west line of said property per Document No. 99-126760 being that portion referred to as Parcel 3 therein (portion of Tax Lot 1700), Assessor Map 1S 2E 23BB;
116. Thence north along the west line of said property per Document No. 99-126760 being the west lines of those portions referred to as Parcels 1 and 3 therein (portion of Tax Lot 1700) to the east right-of-way line of S.E. 122nd Avenue, Assessor Map 1S 2E 23BB;

117. Thence northwesterly across the right-of-way of S.E. 122nd Avenue to a point on the west right-of-way line of S.E. 122nd Avenue at the southeast corner of that property per Document No. 2008-016477, recorded February 29, 2008 (Tax Lot 1000), Assessor Map 1S 2E 22AA and Assessor Map 1S 2E 23 BB;
118. Thence northerly along the west right-of-way line of S.E. 122nd Avenue to the southeast corner of Lot 23 of the plat of "Foster Village", Assessor Map 1S 2E 22AA;
119. Thence westerly along the south lines of Lots 23 and 24 of the plat of "Foster Village", Partition Plat No. 1995-141 and Partition Plat No. 1997-175 to the southwest corner of Partition Plat No. 1997-175, Assessor Map 1S 2E 15DD and Assessor Map 1S 2E 22AA;
120. Thence northerly along the west line of the Partition Plat No. 1997-175 to a point on the south right-of-way line of S.E. Foster Road, Assessor Map 1S 2E 15DD;
121. Thence westerly along said south right-of-way line of S.E. Foster Road to the northeast corner of the plat of "Foster Knoll Condominiums", Assessor Map 1S 2E 15DD;
122. Thence southerly along the east lines of the plat of "Foster Knoll Condominiums" and that property per Book 2601 Page 386, recorded October 16, 1992 (Tax Lot 1300) to the north line of the plat of "Northern Lights, Lots 15 thru 64, Block 3 & Block 4", Assessor Map 1S 2E 15DD, Assessor Map 1S 2E 22AA, and Assessor Map 1S 2E 22AB;
123. Thence westerly along the north lines of the plat of "Northern Lights, Lots 15 thru 64, Block 3 & Block 4" and the plat of "Northern Lights" to the northwest corner of the plat of "Northern Lights", Assessor Map 1S 2E 22AB;
124. Thence southerly along the west line of the plat of "Northern Lights" to a point on the south right-of-way line of S.E. Brookside Drive, Assessor Map 1S 2E 22AB;
125. Thence westerly along said south right-of-way line of S.E. Brookside Drive to the intersection with the east right-of-way line of S.E. 112th Avenue, Assessor Map 1S 2E 22AB;

126. Thence southerly along said west right-of-way line of S.E. 112th Avenue to a point on the easterly prolongation of the south line of Tract "B" of the plat of "Terrace Trails", Assessor Map 1S 2E 22AB and 1S 2E 22AC;
127. Thence westerly along said easterly prolongation and south line of said Tract "B" to the southwest corner thereof, said southwest corner being on the east line of the plat of "Greb Villa", Assessor Map 1S 2E 22BD;
128. Thence northerly along said east line of the plat of "Greb Villa" to the southeast corner of Block D of said plat, Assessor Map 1S 2E 22BC;
129. Thence westerly along the south line of said Block D of the plat of "Greb Villa" to a point on the west line of said plat, Assessor Map 1S 2E 22BC;
130. Thence southerly along said west line of the plat of "Greb Villa" to a point on the northerly right-of-way line of S.E. Knapp Street, Assessor Map 1S 2E 22BC;
131. Thence southwesterly across said right-of-way of S.E. Knapp Street to the northeast corner of Lot 7, Block 2 of the plat of "Wardell Heights", said northeast corner being on the southerly right-of-way line of said S.E. Knapp Street, Assessor Map 1S 2E 22BC;
132. Thence westerly along said southerly right-of-way line of said S.E. Knapp Street to the northeast corner of that property per Document No. 2006-057384, recorded March 31, 2006 (Tax Lot 400), Assessor Map 1S 2E 22BC;
133. Thence southerly along the east line of said property per Document No. 2006-057384 (Tax Lot 400) to the southeast corner thereof, Assessor Map 1S 2E 21A;
134. Thence westerly along the south line of said property per Document No. 2006-057384 (Tax Lot 400) to a point on the southeast right-of-way line of S.E. Knapp Street, Assessor Map 1S 2E 21A;
135. Thence southwesterly along the southeast right-of-way line of S.E. Knapp Street to the northeasterly right-of-way line of Mt. Scott Boulevard (relocated), Assessor Map 1S 2E 21DB;
136. Thence southwesterly to an angle point in the northeast line of Tract "A" of the plat of "Aspen Summit Village", said angle point also being an angle point in the southwest right-of-way of Mt. Scott Boulevard (relocated), said angle point also

- being 305.76 feet from the intersection of the southwest right-of-way line of Mt. Scott Boulevard (relocated) with the north right-of-way line of S.E. Aspen Summit Drive, Assessor Map 1S 2E 21DB;
137. Thence northwesterly along the northeast line of Tract "A" of the plat of "Aspen Summit Village", which is also the southwest right-of-way line of Mt. Scott Boulevard to a point being on the westerly right-of-way line of U.S. Highway I-205, Assessor Map 1S 2E 21DB;
 138. Thence westerly to the intersection of the south right-of-way line of Mt. Scott Boulevard to the west right-of-way line of U.S. Highway I-205, 1S 2E 21DB;
 139. Thence southerly along said west right-of-way line of U.S. Highway I-205 to a point on the east right-of-way line of S.E. 92nd Avenue, Assessor Map 1S 2E 21DB;
 140. Thence southerly along said east right-of-way line of S.E. 92nd Avenue to a point on the south right-of-way line of S.E. Crystal Springs Boulevard, Assessor Map 1S 2E 21DB;
 141. Thence westerly along said south right-of-way line of S.E. Crystal Springs Boulevard to a point on the westerly right-of-way line of U.S. Highway I-205, Assessor Map 1S 2E 21CD;
 142. Thence southerly along the west right-of-way line of U.S. Highway I-205 to a point on the north right-of-way line of S.E. Clatsop Street as shown in the plat of "Panama Villa", Assessor Map 1S 2E 21CD;
 143. Thence westerly along said north right-of-way line of S.E. Clatsop Street to a point on the west right-of-way line of S.E. 87th Avenue, which is also the west line of the plat of "Panama Villa", Assessor Map 1S 2E21CD;
 144. Thence southerly along the west line of the plat of "Panama Villa" to the south line of Section 21, Township 1 South, Range 2 East of the Willamette Meridian, 1S 2E 21 CC;
 145. Thence westerly along the south line of Section 21, Township 1 South, Range 2 East of the Willamette Meridian to the southwest corner of said section, 1S 2E 21 CC;

146. Thence westerly along the south line of Section 20, Township 1 South, Range 2 East of the Willamette Meridian to the west right-of-way line of S.E. 82nd Avenue, Assessor Map 1S 2E 21CC;
147. Thence northerly along said west right-of-way line of S.E. 82nd Avenue to a point on the south right-of-way line of S.E. Flavel Street, Assessor Map 1S 2E 20DD and Assessor Map 1S 2E 20DA;
148. Thence westerly along said south right-of-way line of S.E. Flavel Street to a point on a southerly prolongation of the west right-of-way line of S.E. 78th Avenue, Assessor Map 1S 2E 20DA;
149. Thence northerly along said southerly prolongation and west right-of-way line of S.E. 78th Avenue to a point on the north right-of-way line of S.E. Cooper Street, Assessor Map 1S 2E 20AD and Assessor Map 1S 2E 20AA;
150. Thence easterly along the north right-of-way line of S.E. Cooper Street to a point on the west right-of-way line of S.E.80th Avenue, Assessor Map 1S 2E 20AA;
151. Thence northerly along said west right-of-way line of S.E. 80th Avenue to a point on the south right-of-way line of S.E. Harold Street, Assessor Map 1S 2E 20AA, Assessor Map 1S 2E 17DD, and Assessor Map 1S 2E 17DA;
152. Thence westerly along said south right-of-way line of S.E. Harold Street to the southerly prolongation of the west right-of-way line of S.E. 79th Avenue, Assessor Map 1S 2E 17DA;
153. Thence northerly along the southerly prolongation of the west right-of-way line of S.E. 79th Avenue to the north right-of-way line of S.E. Harold Street, Assessor Map 1S 2E 17DA and Assessor Map 1S 2E 17AD;
154. Thence westerly along the north right-of-way line of S.E. Harold Street to the most southerly, southwest corner of Book 666, Page 328, recorded October 19 , 1914 (Tax Lot 8700), Assessor Map 1S 2E 17AD;
155. Thence northerly along the westerly line of said property per Book 666, Page 328 (Tax Lot 8700) to a point 50 feet east of the right-of-way line of S.E. 77th Avenue, being also 100 feet north of the north right-of-way line of S.E. Harold Street (Tax Lot 8700), Assessor Map 1S 2E 17AD;

156. Thence westerly along the southerly line of said property per Book 666, Page 328 (Tax Lot 8700) to the east right-of-way line of S.E. 77th Avenue, Assessor map 1S 2E 17AD;
157. Thence northerly along the east right-of-way line of S.E. 77th Avenue to the north line of said property per Book 666, Page 328 (Tax Lot 8700), Assessor Map 1S 2E 17AD;
158. Thence westerly along the westerly prolongation of the north line of said property per Book 666, Page 328 (Tax Lot 8700) to a point on the centerline of the right-of-way of S.E. 77th Avenue, Assessor Map 1S 2E 17AD;
159. Thence northerly along said centerline of the right-of-way of S.E. 77th Avenue to a point on the centerline of the right-of-way of S.E. Steele Street, Assessor Map 1S 2E 17AC and Assessor Map 1S 2E 17AD;
160. Thence westerly along said centerline of the right-of-way of S.E. Steele Street to it's intersection with the centerline of the right-of-way of S.E. 74th Avenue, Assessor Map 1S 2E 17AC;
161. Thence northerly along said centerline of the right-of-way of S.E. 74th Avenue to it's intersection with the right-of-way of S.E. Mitchell Court, Assessor Map 1S 2E 17AC;
162. Thence westerly along said centerline of the right-of-way of S.E. Mitchell Court to a point on the centerline of the right-of-way of S.E. 73rd Avenue, Assessor Map 1S 2E 17AC;
163. Thence northerly along said centerline of the right-of-way of S.E. 73rd Avenue to a point on the easterly prolongation of the south line of Lot 26 of the plat of "Anna Marie Park", Assessor Map 1S 2E 17AC;
164. Thence westerly along said easterly prolongation of the south line of Lot 26 of the plat of "Anna Marie Park" to the west right-of-way line of S.E. 73rd Avenue, Assessor Map 1S 2E 17AC;
165. Thence southerly along the west right-of-way line of S.E. 73rd Avenue to the southeast corner of Lot 23 of the plat of "Anna Marie Park", Assessor Map 1S 2E 17AC;

166. Thence westerly along said south line of said Lot 23 of the plat of “Anna Marie Park” to the northeast corner of Lot 21 of said plat, Assessor Map 1S 2E 17AC;
167. Thence southerly along the east line of Lot 21 of the Plat of “Anna Marie Park” to the southeast corner of thereof, Assessor Map 1S 2E 17AC;
168. Thence westerly along the south line of said Lot 21 and Lot 20 of said Plat of “Anna Marie Park” to the southwest corner of said Lot 20, Assessor Map 1S 2E 17AC;
169. Thence southerly along the east line of S.E. Mitchell Street as vacated in Book 1981, Page 1277, recorded February 20, 1987 to it’s intersection with the north line Lot 3, Block 3 of the Plat of “East View”, Assessor Map 1S 2E 17AC;
170. Thence easterly along the north line of Lot 3, Block 3 of the Plat of “East View” to the northeast corner thereof, Assessor Map 1S 2E 17AC;
171. Thence southerly along the east line of said Lot 3, Block 3 of the Plat of “East View” to the southeast corner of thereof, said southeast corner being on the north right-of-way line of S.E. Steele Street, Assessor Map 1S 2E 17AC;
172. Thence westerly along the south line of Lots 3, 2, and 1, Block 3 of the Plat of “East View”, which is also the north right-of-way line of S.E. Steele Street to the east right-of-way line of S.E. 72nd Avenue, Assessor Map 1S 2E 17AC;
173. Thence northerly along the east right-of-way line of S.E. 72nd Avenue to the northwest corner of Lot 11 of the Plat of “Anna Marie Park”, Assessor Map 1S 2E 17AC;
174. Thence westerly along the westerly projection of the north line of said Lot 11 of the Plat of “Anna Marie Park” to it’s intersection with the centerline of the right-of-way line of S.E. 72nd Avenue, Assessor Map 1S 2E 17AC;
175. Thence northerly along the centerline of the right-of-way of S.E. 72nd Avenue to it’s intersection with the easterly projection of the south line of Lot 1, Block 15 of the Plat of “Firland”, Assessor Map 1S 2E 17AC and Assessor Map 1S 2E 17BD;
176. Thence westerly along said easterly projection and the south lines of Lots 1 and 2, 3, 4 and 5, all of Block 15 of the plat of “Firland” to the southwest corner of said Lot 5, Assessor Map 1S 2E 17BD;



177. Thence northerly along the west line of said Lot 5, Block 15 of the plat of "Firland" and it's northerly prolongation to a point on the centerline of the right-of-way of S.E. Raymond Court, Assessor Map 1S 2E 17BD;
178. Thence westerly along said centerline of the right-of-way of S.E. Raymond Court to the centerline of the right-of-way of S.E. 70th Avenue, Assessor Map 1S 2E 17BD;
179. Thence northerly along the centerline of the right-of-way of S.E. 70th Avenue to it's intersection with the easterly prolongation of the south line of Lot 5, Block 11 of the plat of "Firland", Assessor Map 1S 2E 17BD;
180. Thence westerly along said easterly prolongation and the south line of said Lot 5, Block 11 of the plat of "Firland" to the southwest corner thereof, Assessor Map 1S 2E 17BA and Assessor Map 1S 2E 17BD;
181. Thence northerly along the west line of Lot 5, Block 11 of the plat of "Firland" to the southeast corner of that property per Document No. 2001-189105, recorded November 27, 2001 (Tax Lot 12400), Assessor Map 1S 2E 17BA and Assessor Map 1S 2E 17BD;
182. Thence westerly along the south line of said property per Document No. 2001-189105 (Tax Lot 12400) to the southwest corner thereof, Assessor Map 1S 2E 17BA and Assessor Map 1S 2E 17BD;
183. Thence northerly along the west line of said property per Document No. 2001-189105 (Tax Lot 12400) to a point on the south line of that property per Document No. 2002-230880, recorded December 17, 2002 (Tax Lot 11800), Assessor Map 1S 2E 17BA;
184. Thence westerly along the south line of said property per Document No. 2002-230880 (Tax Lot 11800) and it's westerly prolongation to the centerline of the right-of-way of S.E. 67th Avenue, Assessor Map 1S 2E 17BA;
185. Thence northerly along said centerline of the right-of-way line of S.E. 67th Avenue to a point on the easterly prolongation of the south line of Lot 12, Block 6 of the plat of "Arleta Park No. 3", Assessor Map 1S 2E 17BA and Assessor Map 1S 2E 17BB;



186. Thence westerly along said easterly prolongation, the south line of Lot 12, Block 6 of the plat of "Arleta Park No. 3", and it's westerly prolongation to the centerline of the right-of-way of S.E. 66th Avenue, Assessor Map 1S 2E 17BB;
187. Thence northerly along the centerline of the right-of-way of S.E. 66th Avenue to the easterly prolongation of the south line of Lot 13, Block 5 of the plat of "Arleta Park No. 3", Assessor Map 1S 2E 17BB;
188. Thence westerly along said easterly prolongation and the south line of said Lot 13, Block 5 of the plat of "Arleta Park No. 3" to the southwest corner thereof, Assessor Map 1S 2E 17BB;
189. Thence northerly along the west lines of said Lot 13 and Lot 14, all within Block 5 of the plat of "Arleta Park No. 3" to the easterly prolongation of the south line of Lot 28, Block 5 of the plat of "Arleta Park No. 3", Assessor Map 1S 2E 17BB;
190. Thence westerly along said easterly prolongation, the south line of Lot 28, Block 5 of the plat of "Arleta Park No. 3", and it' westerly prolongation to the centerline of the right-of-way of S.E. 65th Avenue, Assessor Map 1S 2E 17BB;
191. Thence northerly along said centerline of the right-of-way of S.E. 65th Avenue to it's intersection with the centerline of the right-of-way of S.E. Schiller Street, Assessor Map 1S 2E 17BB;
192. Thence westerly along said centerline of the right-of-way of S.E. Schiller Street to the southerly projection of the west line of Lot 1, Block 10 of the plat of "Arleta Park No. 3", Assessor Map 1S 2E 17BB;
193. Thence northerly along said southerly projection and the west lines of Lots 1 and 2, all within Block 10 of the plat of "Arleta Park No. 3" to the easterly prolongation of the south line of Lot 15, Block 10 of the plat of "Arleta Park No. 3", Assessor Map 1S 2E 17BB;
194. Thence along said easterly prolongation, the south line of Lot 15, Block 10, of the plat of "Arleta Park No. 3", and it's westerly prolongation to the centerline of the right-of-way of S.E. 64th Avenue, Assessor Map 1S 2E 17BB;
195. Thence northerly along the centerline of the right-of-way of S.E. 64th Avenue to the easterly prolongation of the south line of Lot 19, Block 3 of the plat of "Laurelwood Annex", Assessor Map 1S 2E 17BB;



196. Thence westerly along said easterly prolongation and the south line of said Lot 19, Block 3 of the plat of "Laurelwood Annex" to the southwest corner thereof, Assessor Map 1S 2E 17BB;
197. Thence northerly along the west line of said Lot 19, Block 3 of the plat of "Laurelwood Annex" to the easterly prolongation of the south line of Lot 7, Block 3 of the plat of "Laurelwood Annex", Assessor Map 1S 2E 17BB;
198. Thence westerly along said easterly prolongation, the south line of Lot 7, said Block 3 of the plat of "Laurelwood Annex", and it's westerly prolongation to the centerline of the right-of-way of S.E. 63rd Avenue, Assessor Map 1S 2E 17BB;
199. Thence northerly along the centerline of the right-of-way of S.E. 63rd Avenue to the easterly prolongation of the south line of Lot 24, Block 2 of the plat of "Laurelwood Annex", Assessor Map 1S 2E 17BB;
200. Thence westerly along said easterly prolongation and the south line of Lot 24, Block 2 of the plat of "Laurelwood Annex" to the southwest corner thereof, Assessor Map 1S 2E 17BB;
201. Thence northerly along the west lines of said Lots 24, 25 and 26, all within Block 2 of the plat of "Laurelwood Annex" to a point on the easterly prolongation of the south line of Lot 5, said Block 2 of the plat of "Laurelwood Annex", Assessor Map 1S 2E 17BB;
202. Thence westerly along said easterly prolongation and the south line of said Lot 5, Block 2 of the plat of "Laurelwood Annex" to the southwest corner, said southwest corner being on the east right-of-way line of S.E. 62nd Avenue, Assessor Map 1S 2E 17BB;
203. Thence westerly across said right-of-way of S.E. 62nd Avenue to the southeast corner of that property per Book 911 Page 389, recorded October 05, 1921 (Tax Lot 8300), Assessor Map 1S 2E 17BB;
204. Thence westerly along the south line of said property per Book 911 Page 389 (Tax Lot 8300) and it's westerly prolongation to the centerline of the right-of-way of S.E. 61st Avenue, Assessor Map 1S 2E 17BB and Assessor Map 1S 2E 18AA;



205. Thence northerly along the centerline of the right-of-way of S.E. 61st Avenue to it's intersection with the centerline of the right-of-way of S.E. Holgate Boulevard, Assessor Map 1S 2E 17BB and Assessor Map 1S 2E 18AA;
206. Thence westerly along said centerline of the right-of-way of S.E. Holgate Boulevard to it's intersection with the centerline of the right-of-way of S.E. 61st Avenue, Assessor Map 1S 2E 7DD and Assessor Map 1S 2E 18AA;
207. Thence northerly along said centerline of the right-of-way of S.E. 61st Avenue to a point on the easterly prolongation of the south line of Lot 5 of the plat of "Gray Tract", Assessor Map 1S 2E 7DD;
208. Thence westerly along said prolongation and south line of Lot 5 of the plat of "Gray Tract" to the west line of said plat, Assessor Map 1S 2E 7DD;
209. Thence northerly along said west line of the plat of "Gray Tract" to a point on the southwest right-of-way line of S.E. Foster Road, Assessor Map 1S 2E 7DD;
210. Thence northwesterly along the southwest right-of-way line of S.E. Foster Road to the northeast corner of that property per Document No. 2001-116613, recorded July 27, 2001 (Tax Lot 8200), Assessor Map 1S 2E 7DD;
211. Thence southerly along the east line of said property per Document No. 2001-116613 (Tax Lot 8200) to the southeast corner thereof, Assessor Map 1S 2E 7DD;
212. Thence westerly along the south line of said property per Document No. 2001-116613 (Tax Lot 8200) to the southwest corner thereof; Assessor Map 1S 2E 7DD;
213. Thence northerly along the west line of said document 2001-116613 to the southeast corner of Lot 3, Block 8 of the plat of "Cherry Park", Assessor Map 1S 2E 7DD;
214. Thence westerly along the south lines of Lot 3 and Lot 2, all within Block 8 of the plat of "Cherry Park" to the southwest corner of said Lot 2, said southwest corner being on the east right-of-way line of S.E. 59th Avenue, Assessor Map 1S 2E 7DD;



215. Thence westerly across the right-of-way of S.E. 59th Avenue to the southeast corner of Lot 5, Block 7 in the plat of "Cherry Park", said southeast corner being on the west right-of-way line of S.E. 59th Avenue, Assessor Map 1S 2E 7DD;
216. Thence westerly along the south line of Lot 5, Block 7 of the plat of "Cherry Park" to the southwest corner thereof, Assessor Map 1S 2E 7DD;
217. Thence northerly along the west line of Lot 5, Block 7 of the plat of "Cherry Park" to the northeast corner of Book 1774, Page 72, recorded March 15, 1956 (Tax Lot 14400), Assessor Map 1S 2E 7DD;
218. Thence westerly along the north line of said property per Book 1774, Page 72 (Tax Lot 14400) to the southeast corner of the northwest one-quarter of Lot 1 of Tract F of the plat of "Overton Park, Tracts "E" and "F", said southeast corner also being an angle point in the east line of that property per Book 2535, Page 2723, recorded April 28, 1992 (Tax Lot 14200), Assessor Map 1S 2E 7DD;
219. Thence northerly along the east line of the northwest one-quarter of Lot 1 of Tract F of the plat of "Overton Park, Tracts "E" and "F", which is also along the east line of said property per Book 2535, Page 2723 (Tax Lot 14200) and it's northerly prolongation to the centerline of the right-of-way of S.E. Boise Street, Assessor Map 1S 2E 7DD;
220. Thence westerly along the centerline of the right-of-way of S.E. Boise Street to it's intersection with the southerly prolongation of the west line of Lot 10, Block 1 of the Plat of "Myrtle Park", Assessor Map 1S 2E 7DD;
221. Thence northerly along said southerly prolongation, the west lines of Lots 10 and 17, all within Block 1 of the plat of "Myrtle Park", and their northerly prolongation to it's intersection with the centerline of the right-of-way of S.E. Gladstone Street, Assessor Map 1S 2E 7DD;
222. Thence westerly along said centerline of the right-of-way S.E. Gladstone to it's intersection with the centerline of the right-of-way of S.E. 56th Avenue, Assessor Map 1S 2E 7DC and Assessor Map 1S 2E 7DD;
223. Thence northerly along said centerline of the right-of-way of S.E. 56th Avenue to a point on the easterly prolongation of the south line of Lot 1, Block 2 of the plat of "Archer Place", Assessor Map 1S 2E 7DC;



224. Thence westerly along said easterly prolongation and the south lines of Lots 1 through 6, all within Block 2 of the plat of "Archer Place" to the southwest corner of said Lot 6, Assessor Map 1S 2E 7DC;
225. Thence northerly along the west line of Lot 6, Block 2 of the plat of "Archer Place" to the northwest corner thereof, said northwest corner being on the south right-of-way line of S.E. Center Street, Assessor Map 1S 2E 7DC;
226. Thence easterly along the north line of Lot 6, Block 2 of the plat of "Archer Place", which is also along the south right-of-way line of S.E. Center Street to the northeast corner of said Lot 6, Block 2, Assessor Map 1S 2E 7DC;
227. Thence northerly, perpendicular to the south right-of-way line of S.E. Center Street, to the centerline of the right-of-way of S.E. Center Street, Assessor Map 1S 2E 7DC;
228. Thence westerly along the centerline of the right-of-way of S.E. Center Street to it's intersection with the centerline of the right-of-way of S.E. 54th Avenue, Assessor Map 1S 2E 7DB and Assessor Map 1S 2E 7DC;
229. Thence northerly along said centerline of the right-of-way of S.E. 54th Avenue to the easterly prolongation of the south line of Lot 19, Block 2 of the plat of "Anabel", Assessor Map 1S 2E 7DB;
230. Thence westerly along said easterly projection and the south lines of Lots 19, 18, and 15, Block 2 of the plat of "Anabel" to the southwest corner of said Lot 15, Assessor Map 1S 2E 7DB;
231. Thence northerly along the west line of said Lot 15, Block 2 of the plat of "Anabel" and it's northerly prolongation to it's intersection with the centerline of the right-of-way of S.E. Francis Street, Assessor Map 1S 2E 7DB;
232. Thence westerly along the centerline of the right-of-way of S.E. Francis Street to the southerly prolongation of the west line of Lot 7, Block 1 of the plat of "Anabel", Assessor Map 1S 2E 7DB;
233. Thence northerly along the west line of Lot 7, Block 1 of the plat of "Anabel" to the southeast corner of Lot 4, Block 1 of the plat of "Anabel", Assessor Map 1S 2E 7DB;



234. Thence westerly along the south line of Lot 4, Block 1 of the plat of "Anabel" and it's westerly prolongation to the centerline of the right-of-way of S.E. 52nd Avenue, Assessor Map 1S 2E 7DB;
235. Thence northerly along said centerline of the right-of-way of S.E. 52nd Avenue to the westerly prolongation of the north line of Lot 3, Block 1 of the plat of "Anabel", Assessor Map 1S 2E 7DB;
236. Thence westerly along the westerly prolongation of the north line of said Lot 3, Block 1 of the plat of "Anabel" to the west right-of-way line of S.E. 52nd Avenue, Assessor Map 1S 2E 7DB;
237. Thence northerly along the west right-of-way line of S.E. 52nd Avenue to the southeast corner of Lot 6, Block 7 of the plat of "McGowan Addition", Assessor Map 1S 2E 7DB;
238. Thence westerly along the south lines of Lots 6 and 4, all within Block 7 of the plat of "McGowan Addition" to the southwest corner of said Lot 4, Assessor Map 1S 2E 7DB;
239. Thence northerly along the west line of Lot 4, Block 7 of the plat of "McGowan Addition" and it's northerly prolongation to the centerline of the right-of-way of S.E. Bush Street, Assessor Map 1S 2E 7CA and Assessor Map 1S 2E 7DB;
240. Thence westerly along the centerline of the right-of-way of S.E. Bush Street to the southerly prolongation of the west line of Lot 8, Block 5 of the plat of "McGowan Addition", Assessor Map 1S 2E 7CA;
241. Thence northerly along said south prolongation and the west line of Lot 8, Block 5 of the plat of "McGowan Addition" to the northwest corner thereof, Assessor Map 1S 2E 7CA;
242. Thence northwesterly along the southwest line of Lots 4 and 3, Block 5 of the plat of "McGowan Addition" to an angle point in the southwest line of said Lot 3, which is also the southeast corner of Lot 11, Block 5 of the plat of "McGowan Addition", Assessor Map 1S 2E 7CA;
243. Thence westerly along the south line of Lot 11, Block 5 of the plat of "McGowan Addition" and it's westerly prolongation to a point on the centerline of the right-of-way of S.E. 51st Avenue, Assessor Map 1S 2E 7CA;



244. Thence northerly along said centerline of the right-of-way of S.E. 51st Avenue to it's intersection with the centerline of the right-of-way S.E. Rhone Street, Assessor Map 1S 2E 7CA;
245. Thence westerly along the centerline of the right-of-way of S.E. Rhone Street to it's intersection with the centerline of the right-of-way of S.E. 50th Avenue, Assessor Map 1S 2E 7CA;
246. Thence northerly along the centerline of the right-of-way of S.E. 50th Avenue to a point on the centerline of the right-of-way of S.E. La Fayette Street, Assessor Map 1S 2E 7CA;
247. Thence westerly along the centerline of the right-of-way of S.E. La Fayette Street to the east line of Lot 6, Block 1 of the plat of "North Ivanhoe", Assessor Map 1S 2E 7CA;
248. Thence northerly along the east line of said Lots 6, 5, 4, and 3 , Block 1 of the plat of "North Ivanhoe" to the northeast corner of Lot 3, Block 1 of the plat of "North Ivanhoe", Assessor Map 1S 2E 7CA;
249. Thence westerly along the north line of said Lot 3, Block 1 of the plat of "North Ivanhoe" and it's westerly prolongation to a point on the centerline of the right-of-way of S.E. 49th Avenue, Assessor Map 1S 2E 7CA;
250. Thence northerly along said centerline of the right-of-way line of S.E. 49th Avenue it's intersection with the south right-of-way line of S.E. Powell Boulevard, Assessor Map 1S 2E 7CA;
251. Thence northerly across the right-of-way of S.E. Powell Boulevard to the intersection of the north right-of-way line of S.E. Powell Boulevard with the centerline of the right-of-way of S.E. 49th Avenue, Assessor Map 1S 2E 7BD and Assessor Map 1S 2E 7CA;
252. Thence northerly along the centerline of S.E. 49th Avenue to it's intersection with the centerline of the right-of-way of S.E. Haig Street, Assessor Map 1S 2E 7BD;
253. Thence easterly along said centerline of the right-of-way of S.E. Haig Street to the northerly prolongation of the west line of Lot 5, Block 7 of the plat of "Creston", Assessor Map 1S 2E 7BD;



254. Thence southerly along said northerly prolongation and the west line of Lot 5, Block 7 of the plat of "Creston" to the southwest corner thereof, Assessor Map 1S 2E 7BD;
255. Thence easterly along the south lines of Lots 5 and 11, all within Block 7 of the plat of "Creston" to a point on the west right-of-way line of S.E. 51st Avenue, Assessor Map 1S 2E 7BD;
256. Thence easterly across the right-of-way of S.E. 51st Avenue, to the northwest corner of Lot 27, Block 1 of the Plat of "Creston", said northwest corner being on the east right-of-way line of S.E. 51st Avenue, Assessor Map 1S 2E 7BD;
257. Thence easterly along the north lines of Lot 27 and Lot 28, Block 1 of the plat of "Creston" to the northeast corner of said Lot 28, Block 1, which is also the northwest corner of Lot 1 Block 19 of the Plat of "East Creston", Assessor Map 1S 2E 7BD;
258. Thence easterly along the north line of Lot 1 and Lot 2, all within Block 19 of the plat of "East Creston" to the northeast corner of said Lot 2, Block 19, said northeast corner also being on the west right-of-way line of S.E. 52nd Avenue, Assessor Map 1S 2E 7AC;
259. Thence easterly across the right-of-way of S.E. 52nd Avenue to a point that is 100 feet north of the southwest corner of Block 22 of the plat of "East Creston", said point also being on the east right-of-way line of S.E. 52nd Avenue, Assessor Map 1S 2E 7AC;
260. Thence easterly parallel with the south line of Block 22 of the plat of "East Creston" and it's easterly prolongation to the centerline of the right-of-way of S.E. 53rd Avenue, Assessor Map 1S 2E 7AC;
261. Thence southerly along the centerline of the right-of-way of S.E. 53rd Avenue to it's intersection with the centerline of the right-of-way of S.E. Powell Boulevard, Assessor Map 1S 2E 7AC;
262. Thence southwesterly to the northeast corner of Lot 8, Block 1 of the plat of "Oakdale", Assessor Map 1S 2E 7DB;



263. Thence southerly along the east line of Lot 8, Block 1 of the plat of "Oakdale" to the southeast corner thereof, Assessor Map 1S 2E 7DB;
264. Thence westerly along the south lines of Lot 8 and Lot 7, Block 1 of the plat of "Oakdale" to the southwest corner of said Lot 7, which is also the northwest corner of Lot 28, Block 1 of the plat of "Oakdale", Assessor Map 1S 2E 7DB;
265. Thence southerly along the west lines of Lot 28, Block 1 of the plat of "Oakdale" to the southwest corner thereof, said southwest corner being on the north right-of-way line of S.E. La Fayette Street, Assessor Map 1S 2E 7DB;
266. Thence across the right-of-way of S.E. La Fayette Street to the northwest corner of Lot 7, Block 4 of the plat of "Oakdale", said northwest corner being on the south right-of-way line of S.E. La Fayette Street, Assessor 1S 2E 7DB;
267. Thence southerly along the west lines of Lot 7 and Lot 28, all within Block 4 of the plat of "Oakdale" and it's southerly prolongation to the centerline of the right-of-way of S.E. Rhone Street, Assessor Map 1S 2E 7DB;
268. Thence easterly along the centerline of the right-of-way of S.E. Rhone Street to it's intersection with the centerline of the right-of-way of S.E. 54th Avenue, Assessor Map 1S 2E 7DB;
269. Thence southerly along the centerline of the right-of-way of S.E. 54th Avenue to it's intersection with the centerline of the right-of-way of S.E. Bush Street, Assessor Map 1S 2E 7DB;
270. Thence easterly along the centerline of the right-of-way of S.E. Bush Street to the northerly prolongation of the east line of that property per Book 751 Page 275, recorded September 14, 1970 (Tax Lot 7300), Assessor Map 1S 2E 7DB;
271. Thence southerly along said northerly prolongation and the east line of said property per Book 751 Page 275 (Tax Lot 7300) to a point on the north line of Lot 16, Block 2 of the plat of "Cannon's Addition", Assessor Map 1S 2E 7DB;
272. Thence easterly along the north lines of Lots 16 through 20, all within Block 2 of the plat of "Cannon's Addition" and their easterly prolongation to the intersection with the centerline of the right-of-way of S.E. 56th Avenue, Assessor Map 1S 2E 7DB;



273. Thence southerly along said centerline of the right-of-way of S.E. 56th Avenue to it's intersection with the centerline of the right-of-way of S.E. Francis Street, Assessor Map 1S 2E 7DB;
274. Thence easterly along said centerline of the right-of-way of S.E. Francis Street to the northerly prolongation of the east line of Lot 7, Block 2 of the plat of "Watt's Subdivision", Assessor Map 1S 2E 7DB;
275. Thence southerly along said northerly prolongation and the east lines of Lots 7 and 14, all within Block 2 of the plat of "Watt's Subdivision" and their southerly prolongation to the intersection with the centerline of the right-of-way of S.E. Center Street, Assessor Map 1S 2E 7DA and Assessor Map 1S 2E 7DB;
276. Thence easterly along said centerline of the right-of-way of S.E. Center Street to it's intersection with the centerline of the right-of-way of S.E. 58th Avenue, Assessor Map 1S 2E 7DA and Assessor Map 1S 2E 7DD;
277. Thence southerly along said centerline of the right-of-way of S.E. 58th Avenue to a point on a westerly prolongation of the north line of Lot 11, Block 3, plat of "Myrtle", Assessor Map 1S 2E 7DD;
278. Thence easterly along said westerly prolongation and the north lines of Lots 11 through 16, all within Block 3 of the plat of "Myrtle" to the northeast corner of said Lot 16, Block 3, Assessor Map 1S 2E 7DD;
279. Thence southerly along the east line of Lot 16, Block 3 of the plat of "Myrtle" and it's southerly prolongation to it's intersection with the centerline of the right-of-way of S.E. Gladstone Street, Assessor Map 1S 2E 7DD;
280. Thence easterly along said centerline of the right-of-way of S.E. Gladstone Street to it's intersection with the centerline of the right-of-way of S.E. 60th Avenue, Assessor Map 1S 2E 7DD;
281. Thence southerly along said centerline of the right-of-way of S.E. 60th Avenue to a point on a westerly prolongation of the south line of Lot 12, Block 3 of the plat of "Stewart Park", Assessor Map 1S 2E 7DD;
282. Thence easterly along said westerly prolongation and the south lines of Lots 12 through 16, all within Block 3 of the plat of "Stewart Park" to the northeast corner of Lot 7, Block 3 of the plat of "Stewart Park", Assessor Map 1S 2E 7DD;



283. Thence southerly along the east line of Lot 7, Block 3 of the plat of "Stewart Park" and it's south prolongation to the centerline of the right-of-way of S.E. Boise Street, Assessor Map 1S 2E 7DD;
284. Thence easterly along the centerline of the right-of-way of S.E. Boise Street to the northerly prolongation of the east line of Lot 16, Block 2, of the plat of "Stewart Park", Assessor Map 1S 2E 7DD;
285. Thence southerly along said northerly prolongation and the east line of Lot 16, Block 2 of the plat of "Stewart Park" to the southeast corner thereof, said southeast corner also being the northwest corner of Lot 3, Block 2 of the plat "Stewart Park", Assessor Map 1S 2E 7DD;
286. Thence easterly along the north lines of Lots 3, 2, and 1, all within Block 2 of the plat of "Stewart Park" and their easterly prolongation to the intersection with the centerline of the right-of-way of S.E. 62nd Avenue, Assessor Map 1S 2E 7DD;
287. Thence southerly along the centerline of the right-of-way of S.E. 62nd Avenue to it's intersection with westerly prolongation of the north line of Lot 4, Block 10 of the plat of "Laurelwood", Assessor Map 1S 2E 7DD and Assessor Map 1S 2E 8CC;
288. Thence easterly along said westerly prolongation, the north line of Lot 4, Block 10 of the plat of "Laurelwood", and it's easterly prolongation to the west line of Lot 22, Block 10 of said plat of "Laurelwood", Assessor Map 1S 2E 8CC;
289. Thence southerly along the west line of Lots 22 and 21, all within Block 10 of the plat of "Laurelwood" to the southwest corner of said Lot 21, Block 10, which is also to the northwest corner of Lot 20, Block 10 of the plat of "Laurelwood", Assessor Map 1S 2E 8CC;
290. Thence easterly along the north line of Lot 20, Block 10 of the plat of "Laurelwood" and it's easterly prolongation to a point on the centerline of the right-of-way of S.E. 63rd Avenue, Assessor Map 1S 2E 8CC;
291. Thence southerly along the centerline of the right-of-way of S.E. 63rd Avenue to a point on the westerly prolongation of the north line of Lot 8, Block 9 of the plat of "Laurelwood", Assessor Map 1S 2E 8CC;



292. Thence easterly along said westerly prolongation and north line of Lot 8, Block 9 of the plat of "Laurelwood" and it's easterly prolongation to the west line of Lot 23, Block 9 plat of "Laurelwood", Assessor Map 1S 2E 8CC;
293. Thence southerly along the west lines of Lots 23 and 22, all within Block 9 of the plat of "Laurelwood" to the southwest corner of said Lot 22, Block 9, which is also the northwest corner of Lot 21, Block 9 of the plat of "Laurelwood, Assessor Map 1S 2E 8CC;
294. Thence easterly along said north line of Lot 21, Block 9 of the plat of "Laurelwood" to a point on the west right-of-way line of S.E. 64th Avenue, Assessor Map 1S 2E 8CC;
295. Thence southerly along the west right-of-way line of S.E. 64th Avenue to a point on the westerly prolongation of the north line of Lot 13, Block 8 of the plat of "Laurelwood", Assessor Map 1S 2E 8CC;
296. Thence easterly along said westerly prolongation and the north line of Lot 13, Block 8, plat of "Laurelwood" to the northeast corner thereof, Assessor Map 1S 2E 8CC;
297. Thence easterly across the alley to the northwest corner of Lot 18, Block 8, plat of "Laurelwood", Assessor Map 1S 2E 8CC;
298. Thence easterly along the north line of Lot 18, Block 8, plat of "Laurelwood" and it's easterly prolongation to the centerline of the right-of-way of S.E. 65th Avenue, Assessor Map 1S 2E 8CC;
299. Thence southerly along the centerline of the right-of-way of S.E. 65th Avenue to it's intersection with the centerline of the right-of-way of S.E. Holgate Boulevard, Assessor Map 1S 2E 8CC;
300. Thence easterly along the centerline of the right-of-way line of S.E. Holgate Boulevard to it's intersection with the centerline of the right-of-way line of S.E. 65th Avenue, Assessor Map 1S 2E 8CC and Assessor Map 1S 2E 17BB;
301. Thence southerly along the centerline of the right-of-way of S.E. 65th Avenue a point on the westerly prolongation of the south line of Lot 14, Block 8 of the plat of "Arleta Park No. 3", Assessor Map 1S 2E 17BB;



302. Thence easterly along said westerly prolongation and the south line of Lot 14, Block 8 of the plat of "Arleta Park No. 3" to the southeast corner thereof, Assessor Map 1S 2E 17BB;
303. Thence northerly along the east line of said Lot 14, Block 8 of the plat of "Arleta Park No. 3" to the westerly prolongation of the north line of Lot 7, Block 8 of the plat of "Arleta Park No. 3", Assessor Map 1S 2E 17BB;
304. Thence easterly along said westerly prolongation and the north line of Lot 7, Block 8 of the plat of "Arleta Park No. 3" to a point on the west right-of-way line of S.E. 66th Avenue, Assessor Map 1S 2E 17BB;
305. Thence southerly along the west right-of-way line of S.E. 66th Avenue to the southeast corner of Lot 7, Block 8 of the plat of "Arleta Park No. 3", Assessor Map 1S 2E 17BB;
306. Thence easterly along the easterly prolongation of the south line of Lot 7, Block 8 of the plat of "Arleta Park No. 3" to its intersection with the centerline of the right-of-way of S.E. 66th Avenue, Assessor Map 1S 2E 17BB;
307. Thence northerly along the centerline of the right-of-way of S.E. 66th Avenue to the westerly prolongation of the north line of Lot 10, Block 7 of the plat of "Arleta Park No. 3", Assessor Map 1S 2E 17BB;
308. Thence easterly along said westerly prolongation, the north line of Lot 10, Block 7 of the plat of "Arleta Park No. 3", and its easterly prolongation to a point on the centerline of the right-of-way of S.E. 67th Avenue, Assessor Map 1S 2E 17BB;
309. Thence southeasterly to the northwest corner of Lot 9, Block 11 of the plat of "Supplemental Plat of Kern Park", said northwest corner being on the east right-of-way line of S.E. 67th Avenue, Assessor Map 1S 2E 17BA;
310. Thence easterly along the north line of Lot 9, Block 11 of the plat of "Supplemental Plat of Kern Park" to the northeast corner thereof, Assessor Map 1S 2E 17BA;
311. Thence southerly along the east lines of Lots 9 and 8, all within Block 11 of the plat of "Supplement Plat of Kern Park" to the southeast corner of said Lot 8,



- Block 11, said southeast corner being on the north right-of-way line of S.E. Pardee Street;
312. Thence southwesterly across the right-of-way of S.E. Pardee Street to the northeast corner of that property per Document No. 2007-0011646, recorded January 22, 2007, said northeast corner being on the south right-of-way line of S.E. Pardee Street, Assessor Map 1S 2E 17BA;
 313. Thence southerly along the east line of said Document No. 2007-0011646 property to the southeast corner thereof, said southeast corner being on the south line of Lot 13, Block 12 of the plat of "Supplemental Plat of Kern Park", Assessor Map 1S 2E 17BA;
 314. Thence easterly along the south line of Lot 13, Block 12 of the plat of "Supplemental Plat of Kern Park" to the northeast corner of that property per Document No. 2001-0077050, recorded May 25, 2001, Assessor Map 1S 2E 17BA;
 315. Thence southerly along the east line of said Document No. 2001-0077050 property and its southerly prolongation to a point on the north line of Lot 11, Block 12 of the plat of "Supplemental Plat of Kern Park", Assessor Map 1S 2E 17BA;
 316. Thence easterly along the north lines of Lot 11 and Lots 1 through 7, all within Block 12 of the plat of "Supplemental Plat of Kern Park" and their easterly prolongation to the intersection with the centerline of the right-of-way of S.E. 69th Avenue, Assessor Map 1S 2E 17BA;
 317. Thence southerly along the centerline of the right-of-way of S.E. 69th Avenue to its intersection with the centerline of the right-of-way of S.E. Long Street, Assessor Map 1S 2E 17BA;
 318. Thence easterly along the centerline of the right-of-way of S.E. Long Street and its easterly prolongation to a point on the west line of Lot 11, Block 10 of the plat of "Firland", Assessor Map 1S 2E 17BA;
 319. Thence southerly along the west lines of Lots 11, 12, and 13, all within Block 10 of the plat of "Firland" to the southwest corner of said Lot 13, Block 10, which is also at the northwest corner of Lot 14, Block 10 of the plat of "Firland", Assessor Map 1S 2E 17BA;



320. Thence easterly along the north line of Lot 14, Block 10 of the plat of "Firland" and its easterly prolongation to its intersection with the centerline of the right-of-way of S.E. 70th Avenue, Assessor Map 1S 2E 17BA;
321. Thence southerly along the centerline of the right-of-way of S.E. 70th Avenue to a point on the westerly prolongation of the south line of Lot 13, Block 8 of the plat of "Firland", Assessor Map 1S 2E 17BA;
322. Thence easterly along said westerly prolongation, the south lines of Lots 13 and 3, Block 8 of the plat of "Firland", and their easterly prolongation to the intersection with the centerline of the right-of-way of S.E. 71st Avenue, Assessor Map 1S 2E 17BA;
323. Thence southerly along the centerline of the right-of-way of S.E. 71st Avenue to a point on the westerly prolongation of the north line of Lot 16, Block 7 of the plat of "Firland", Assessor Map 1S 2E 17BA;
324. Thence easterly along said westerly prolongation and north line of Lot 16, Block 7 of the plat of "Firland" to the northeast corner thereof, Assessor Map 1S 2E 17BA;
325. Thence southerly along the east line of Lot 16, Block 7 of the plat of "Firland" to the southeast corner thereof, also being the northwest corner of Lot 7, Block 7 said plat of "Firland", Assessor Map 1S 2E 17BA;
326. Thence easterly along the north line of Lot 7, Block 7 of said plat of "Firland" and its easterly prolongation to the intersection with the centerline of the right-of-way of S.E. 72nd Avenue, which is platted as West Firland Avenue on the plat of "Firland", Assessor Map 1S 2E 17BA;
327. Thence southerly along the centerline of the right-of-way line of S.E. 72nd Avenue, which is platted as West Firland Avenue in the plat of "Firland" to its intersection with the north right-of-way line of S.E. Foster Road, Assessor Map 1S 2E 17AB and Assessor Map 1S 2E 17BA;
328. Thence easterly along said north right-of-way line of S.E. Foster Road to a point on the centerline of the right-of-way line of S.E. 72nd Avenue, which is platted as East Firland Avenue in the plat of "Firland", Assessor Map 1S 2E 17BA;



329. Thence northerly along the centerline of the right-of-way line of S.E. 72nd Avenue, which is platted as East Firland Avenue in the plat of "Firland" to the westerly prolongation of the north line of Lot 14, Block 4 of the plat of "Firland", Assessor Map 1S 2E 17AB;
330. Thence easterly along said westerly prolongation, the north lines of Lots 14 and 11, all within Block 4 of the plat of "Firland", and their easterly prolongation to the centerline of the right-of-way of S.E. 73rd Avenue, Assessor Map 1S 2E 17AB;
331. Thence southerly along said centerline of the right-of-way of S.E. 73rd Avenue to a point on the centerline of the right-of-way of S.E. Raymond Street, Assessor Map 1S 2E 17AB;
332. Thence easterly along the centerline of the right-of-way of S.E. Raymond Street to the centerline of the right-of-way of S.E. 75th Avenue, Assessor Map 1S 2E 17AB and Assessor Map 1S 2E 17AC;
333. Thence southerly along said centerline of the right-of-way of S.E. 75th Avenue to a point on the westerly prolongation of the north line of Lot 4, Block 3 of the plat of "Edgecombe, Blocks 2 and 3", Assessor Map 1S 2E 17AC;
334. Thence easterly along said westerly prolongation and the north line of Lot 4, Block 3 of the plat of "Edgecombe, Blocks 2 and 3" to the northeast corner thereof, Assessor Map 1S 2E 17AC;
335. Thence southerly along the east line of Lot 4, Block 3 of the plat of "Edgecombe, Blocks 2 and 3" to the northwest corner of Lot 9, Block 3 of the plat of "Edgecombe, Blocks 2 and 3", Assessor Map 1S 2E 17AC;
336. Thence easterly along the north line of Lot 9, Block 3 of the plat of "Edgecombe, Blocks 2 and 3" to a point on the west right-of-way line of S.E. 76th Avenue, Assessor Map 1S 2E 17AC;
337. Thence southerly along the west right-of-way line of S.E. 76th Avenue to a point on the westerly prolongation of the north line of that property per Document No. 2007-101105, recorded June 6, 2007 (Tax Lot 2000), Assessor Map 1S 2E 17AC;



338. Thence easterly along said westerly prolongation and north line of said property per Document No. 2007-101105 (Tax Lot 2000) to a point on the west line of Lot 7, Block 3 of the plat of "Chicago Centre", Assessor Map 1S 2E 17AC;
339. Thence southerly along the west line of Lots 7 through 10, Block 3 of the plat of "Chicago Centre" to the northwest corner of Lot 11, Block 3 of the plat of "Chicago Centre", Assessor Map 1S 2E 17AC;
340. Thence easterly along the north line of Lot 11, Block 3 of the plat of "Chicago Centre" and it's easterly prolongation to a point on the centerline of the right-of-way of S.E. 77th Avenue, Assessor Map 1S 2E 17AC;
341. Thence southerly along said centerline of the right-of-way of S.E. 77th Avenue to it's intersection with the centerline of the right-of-way of S.E. Mitchell Street, Assessor Map 1S 2E 17AC;
342. Thence easterly along the centerline of the right-of-way of S.E. Mitchell Street to it's intersection with the centerline of the right-of-way of S.E. 78th Avenue, Assessor Map 1S 2E 17AC and Assessor Map 1S 2E 17AD;
343. Thence southerly along said centerline of the right-of-way of S.E. 78th Avenue to a point on the westerly prolongation of the north line of Lot 5, Block 5 of the plat of "Chicago Centre", Assessor Map 1S 2E 17AD;
344. Thence easterly along said westerly prolongation and north line of Lot 5, Block 5 of the plat of "Chicago Centre" to the northeast corner thereof, Assessor Map 1S 2E 17AD;
345. Thence southerly along the east lines of Lots 5 through 8, all within Block 5 of the plat of "Chicago Centre" to the southwest corner of that property per Book 2131 Page 234, recorded August 23, 1988, Assessor Map 1S 2E 17AD;
346. Thence easterly along the south line of said property per Book 2131 Page 234 to a point on the west line of Lot 5, Block 5 of the plat of "Rosemary Park", Assessor Map 1S 2E 17AD;
347. Thence southerly along the west line of Lot 5, Block 5 of the plat of "Rosemary Park" to the southwest corner thereof, Assessor Map 1S 2E 17AD;



348. Thence easterly along the south line of said Lot 5, Block 5 of the plat of "Rosemary Park" to a point on the west right-of-way line of S.E. 79th Avenue, Assessor Map 1S 2E 17AD;
349. Thence northerly along said west right-of-way line of S.E. 79th Avenue to a point on the south right-of-way line of S.E. Raymond Street, Assessor Map 1S 2E 17AD;
350. Thence northeasterly to a point at the intersection of the west right-of-way line of S.E. 79th Avenue and the north right-of-way line of S.E. Raymond Street, Assessor Map 1S 2E 17AA and 1S 2E 17AD;
351. Thence westerly along said north right-of-way line of S.E. Raymond Street, to a point on the east right-of-way line of S.E. 77th Avenue, Assessor Map 1S 2E 17AA;
352. Thence northerly along said east right-of-way line of S.E. 77th Avenue, to a point on the south right-of-way line of S.E. Long Street, Assessor Map 1S 2E 17AA and Assessor Map 1S 2E 17AB;
353. Thence easterly along said south right-of-way line of S.E. Long Street to the northeast corner of that property per Document No. 2007-191384, recorded November 2, 2007 (Tax Lot 5000), Assessor Map 1S 2E 17AA and Assessor Map 1S 2E 17AB;
354. Thence southerly along the east line of said property per Document No. 2007-191384 (Tax Lot 5000) to the southeast corner thereof, said southeast corner being on the south line of the plat of "Pembroke", Assessor Map 1S 2E 17AA;
355. Thence easterly along the south line of the plat of "Pembroke" to the southwest corner of that property per Document No. 2006-070966, recorded April 19, 2006 (Tax Lot 5500), Assessor Map 1S 2E 17AA;
356. Thence northerly along the west line of said property per Document No. 2006-070966 (Tax Lot 5500) to the northwest corner thereof, said northwest corner being on the south right-of-way line of S.E. Long Street, Assessor Map 1S 2E 17AA;
357. Thence easterly along said south right-of-way line of S.E. Long Street to a point on the west right-of-way line of S.E. 79th Avenue, Assessor Map 1S 2E 17AA;



358. Thence northerly along said west right-of-way line of S.E. 79th Avenue to a point on the south right-of-way line of S.E. Holgate Boulevard, Assessor Map 1S 2E 17AA;
359. Thence westerly along said south right-of-way line of S.E. Holgate Boulevard to a point on the southerly prolongation of the west right-of-way line of S.E. 79th Avenue, Assessor Map 1S 2E 17AA;
360. Thence northerly along said southerly prolongation and the west right-of-way line of S.E. 79th Avenue and its northerly prolongation to a point on the north right-of-way line of S.E. Powell Boulevard, said point being the POINT OF BEGINNING, Assessor Map 1S 2E 8DA.

EXCEPTING THEREFROM that tract of land situated in the southwest one-quarter of Section 14, Township 1 South, Range 2 East of the Willamette Meridian, City of Portland, County of Multnomah, State of Oregon, more particularly described as follows:

Commencing at the intersection of the northwest corner of Parcel II of Partition Plat No. 1991-028, said northwest corner being on the south right-of-way line of S.E. Ramona Street, Assessor Map 1S 2E 14CB:

361. Thence easterly along the south right-of-way line of S.E. Ramona Street to the northeast corner of Parcel I of Partition Plat No. 1991-028, said northeast corner being on the west line of that property per Document No. 99-214280, recorded November 24, 1999 and referred to as Parcel 6 therein (portion of Tax Lot 13800), Assessor Map 1S 2E 14CB;
362. Thence southerly along the west line of said property per Document No. 99-214280 referred to as Parcel 6 therein (portion of Tax Lot 13800 and a portion of Tax Lot 1600), a portion of said west line also being along the east line of Partition Plat No. 1991-028 to the southwest corner of said Parcel 6, Assessor Map 1S 2E 14CB and Assessor Map 1S 2E 14CC;
363. Thence easterly along the south line of said property per Document No. 99-214280 referred to as Parcel 6 therein (portion of Tax Lot 1600) to the west line of said property per Document No. 99-214280 and referred to as Parcel 4 therein (portion of Tax Lot 1600), Assessor Map 1S 2E 14 CC;

364. Thence southerly along the west lines of said property per Document No. 99-214280 referred to as Parcel 4 therein and referred to as Parcel 7 therein (portion of Tax Lot 1600) to the northeast corner of that property per Document No. 2006-160310, recorded August 28, 2006 (Tax Lot 4700), Assessor Map 1S 2E 14 CC;
365. Thence westerly along the north line of said property per Document No. 2006-160310 (Tax Lot 4700) and the north lines of those properties per Document No. 2006-159267, recorded August 25, 2006 (Tax Lot 4600) and Document No. 2005-089541, recorded May 18, 2005 (Tax Lots 4300, 4400, and 4500) to a point on the east line that property per Document No. 2004-045399, recorded March 19, 2004 (Tax Lot 3900), Assessor Map 1S 2E 14CC;
366. Thence northerly along the east line of said property per Document No. 2004-045399 (Tax Lot 3900) to the northeast corner thereof, Assessor Map 1S 2E 14CC;
367. Thence westerly along the north line of said property per Document No. 2004-045399 (Tax Lot 3900) to the east right-of-way line of S.E. 122nd Avenue, Assessor Map 1S 2E 14CC
368. Thence northerly along said east right-of-way line of S.E. 122nd Avenue to the south line of that property per Document No. 2007-203358, recorded November 27, 2007 (Tax Lot 14100), Assessor Map 1S 2E 14CB and Assessor Map 1S 2E 14CC;
369. Thence easterly along the south line of said property per Document No. 2007-203358 (Tax Lot 14100) to the southeast corner thereof, said southeast corner also being the southwest corner of Partition Plat No. 1991-028, Assessor Map 1S 2E 14CB and Assessor Map 1S 2E 14CC;
370. Thence northerly along the east line of said property per Document No. 2007-203358 (Tax Lot 14100), which is also along the west line of Partition Plat No. 1991-028 to the point of commencement, Assessor Map 1S 2E 14CB and Assessor Map 1S 2E 14CC.

ALSO EXCEPTING THEREFROM the following SIX (6) described tracts along the U.S. Highway I-205 corridor:



Situated in the S.E. 1/4 of Section 9, the N.E. 1/4 and S.E. 1/4 of Section 16 and the N.E. 1/4 of Section 21, all within Township 1 South, Range 2 East of the Willamette Meridian, City of Portland, County of Multnomah, State of Oregon;

TRACT 1

Beginning at a point of intersection of a line that is 200.00 feet south of the centerline of S.E. Powell Boulevard with the east right-of-way line of U.S. Highway I-205 as shown in ODOT Drawing No. 9B-1-25, said east line being also the east right-of-way line of S.E. 97th Avenue as originally shown in the plat of "Skagway Heights, Blocks 4, 5, & 6 Inc.", Assessor Map 1S 2E 9 and Assessor Map 1S 2E 9DB:

371. Thence southerly along the east right-of-way line of U.S. Highway I-205, said east line being also the east right-of-way line of S.E. 97th Avenue as originally shown in the plat of "Skagway Heights, Blocks 4, 5, & 6 Inc." to the easterly prolongation of the south line of Lot 34, Block 5 of said plat, Assessor Map 1S 2E 9 and Assessor Map 1S 2E 9DB;
372. Thence westerly along the east right-of-way line of U.S. Highway I-205, said east line being also the south line of Lot 34, Block 5 as shown in the plat of "Skagway Heights, Blocks 4, 5, & 6 Inc." to Station 432+48.88, a distance of 233.24 feet left of centerline of U.S. Highway I-205 as shown in ODOT Drawing No. 9B-1-25, Assessor Map 1S 2E 9 and Assessor Map 1S 2E 9DB;
373. Thence southerly along the east right-of-way line of U.S. Highway I-205 as shown in ODOT Drawing No. 9B-1-25 to Station 442+86.75, a distance of 156.04 feet left of centerline as shown in said drawing to the north line of Lot 7, Block 2 as shown in the plat of "Skagway Heights", Assessor Map 1S 2E 9 and Assessor Map 1S 2E 9DB;
374. Thence westerly along the north line of Lot 7, Block 2 as shown in the plat of "Skagway Heights" to the northwest corner thereof, Assessor Map 1S 2E 9DC;
375. Thence southerly along the west line of Lot 7, Block 2 as shown in the plat of "Skagway Heights" to the southwest corner thereof, Assessor Map 1S 2E 9DC;
376. Thence easterly along the south line of Lot 7, Block 2 as shown in the plat of "Skagway Heights" to the east right-of-way line of U.S. Highway I-205 as shown in ODOT Drawing No. 9B-1-25, which is also the west line of the plat of "Leeh Estates", Assessor Map 1S 2E 9DC;

377. Thence southerly along the east right-of-way line of U.S. Highway I-205 as shown in ODOT Drawing No. 9B-1-25, which is also the west line of the plat of "Leeh Estates" to the southwest corner of said plat, Assessor Map 1S 2E 9DC;
378. Thence easterly along the south line of the plat of "Leeh Estates" to the northwest corner of the east, 68.5 feet of Lot 17, Block 2 as shown in the plat of "Skagway Heights", Assessor Map 1S 2E 9DC;
379. Thence southerly along the east right-of-way line of U.S. Highway I-205, which is also along the west line of the east, 68.5 feet of Lot 17, Block 2 as shown in the plat of "Skagway Heights" and along the west line of Lot 19, Block 2 as shown in said plat to the southwest corner of said Lot 19, Assessor Map 1S 2E 9DC;
380. Thence southerly along the east right-of-way line of U.S. Highway I-205 to the northwest corner of that property per Book 2786, Page 1798 (Tax Lot 2100), recorded November 19, 1993, Assessor Map 1S 2E 9DC;
381. Thence southerly along the east right-of-way line of U.S. Highway I-205, which is also along the west line of said Book 2786, Page 1798 property to the southwest corner of said property, Assessor Map 1S 2E 9DC;
382. Thence easterly along the south line of said Book 2786, Page 1798 property to the northwest corner of Lot 9, Block 1 as shown in the plat of "Elmo Heights", Assessor Map 1S 2E 9DC;
383. Thence southerly along the east right-of-way line of U.S. Highway I-205, which is also along the west line of Lot 9, Block 1 as shown in the plat of "Elmo Heights" to the north right-of-way line of S.E. Cora Street as shown in said plat, Assessor Map 1S 2E 9DC;
384. Thence westerly along the right-of-way of U.S. Highway I-205, which is also along the north right-of-way line of S.E. Cora Street as shown in the plat of "Elmo Heights" to the west right-of-way line of S.E. 96th Avenue as shown in said plat, Assessor Map 1S 2E 9DC;
385. Thence southerly along the east right-of-way of U.S. Highway I-205, which is also along the west right-of-way line of S.E. 96th Avenue as shown in the plat of "Elmo Heights" to a line that is 100.00 feet north of the centerline of S.E. Holgate Boulevard, Assessor Map 1S 2E 9DC;



386. Thence, leaving the east right-of-way line of U.S. Highway I-205, westerly along a line that is 100.00 feet north of the centerline of S.E. Holgate Boulevard to a point that bears South $86^{\circ}35'20''$ East, a distance of 261.77 feet and North $03^{\circ}24'40''$ East, a distance of 60.00 feet from the intersection of the north right-of-way line of S.E. Powell Boulevard with the west right-of-way line of U.S. Highway I-205 as shown in ODOT Drawing No. 9B-1-25, Assessor Map 1S 2E 9DC;
387. Thence North $05^{\circ}45'00''$ East, a distance of 1061.43 feet to a point of curvature, Assessor Map 1S 2E 9DC;
388. Thence along the arc of a 3,400.00 foot radius curve, concave westerly, through a central angle of $08^{\circ}01'55''$, the long chord of which bears North $01^{\circ}44'03''$ East, a distance of 476.23 feet, an arc distance of 476.62 feet to a point of tangency, Assessor Map 1S 2E 9DB and Assessor Map 1S 2E 9DC;
389. Thence North $02^{\circ}16'55''$ West, a distance of 276.78 feet, Assessor Map 1S 2E 9DB;
390. Thence North $04^{\circ}33'50''$ West, a distance of 345.60 feet, Assessor Map 1S 2E 9DB;
391. Thence North $06^{\circ}51'59''$ West, a distance of 259.29 feet, more or less to a point on a line that is 200.00 feet south of the centerline of S.E. Powell Boulevard, said point bearing South $88^{\circ}16'15''$ East, a distance of 558.19 feet and South $01^{\circ}43'45''$ West, a distance of 200.00 feet from the intersection of the centerline right-of-way of S.E. Powell Boulevard with the centerline of the portion S.E. 92nd Avenue that runs northerly of S.E. Powell Boulevard, Assessor Map 1S 2E 9DB;
392. Thence easterly along a line that is 200.00 feet south of the centerline of S.E. Powell Boulevard to the point of beginning, Assessor Map 1S 2E 9DB.

TRACT 2

Beginning at a point of intersection of a line that is 100.00 feet south of the centerline of S.E. Holgate Boulevard with the east right-of-way line of U.S. Highway I-205, which is also the west right-of-way line of S.E. 96th Avenue as originally shown in the plat of "Cadwell's Addition", Assessor Map 1S 2E 16AB:

393. Thence southerly along the east right-of-way line of U.S. Highway I-205, which is also the west right-of-way line of S.E. 96th Avenue as shown in the plat of "Cadwell's Addition" to the south right-of-way line of S.E. Schiller Street as shown in said plat, Assessor Map 1S 2E 16AB;
394. Thence easterly along the south right-of-way line of S.E. 96th Avenue as shown in the plat of "Cadwell's Addition" to the right-of-way centerline of S.E. 96th Avenue as shown in said plat, Assessor Map 1S 2E 16AB;
395. Thence southerly along the east right-of-way line of U.S. Highway I-205, which is also along the right-of-way centerline S.E. 96th Avenue as shown in the plat of "Cadwell's Addition", said right-of-way of S.E. 96th Avenue now vacated, to the south line of said plat, Assessor Map 1S 2E 16 and Assessor Map 1S 2E 16AB;
396. Thence easterly along the south line of the plat of "Cadwell's Addition" to the northwest corner of Lot "C" as shown in the plat of "School Park", Assessor Map 1S 2E 16, Assessor Map 1S 2E 16AB, and Assessor Map 1S 2E 16AC;
397. Thence southerly along the west line of Lot "C" as shown in the plat of "School Park" to a point that is 50.00 feet north of the southwest corner of said Lot "C", said southwest corner being on the centerline of the right-of-way shown in said plat, Assessor Map 1S 2E 16 and Assessor Map 1S 2E 16AC;
398. Thence North $86^{\circ}36'00''$ West, a distance of 362.86 feet, Assessor Map 1S 2E 16AC;
399. Thence North $00^{\circ}27'40''$ West, a distance of 526.16 feet to a point of curvature, Assessor Map 1S 2E 16AC;
400. Thence along the arc of a 12500.00 foot radius curve, concave easterly, through a central angle of $04^{\circ}53'00''$, the long chord of which bears North $01^{\circ}54'10''$ East, a distance of 1065.08 feet, an arc distance of 1065.41 feet to a point of tangency, Assessor Map 1S 2E 16AB and Assessor Map 1S 2E 16AC;
401. Thence North $05^{\circ}20'40''$ East, a distance of 272.82 feet, more or less to a point on a line that is 100.00 feet south of the centerline of S.E. Holgate Boulevard, said point bearing South $86^{\circ}35'20''$ East, a distance of 206.96 feet and South $03^{\circ}24'40''$ West, a distance of 60.00 feet from the intersection of the south right-



of-way of S.E. Holgate Boulevard with the west right-of-way line of U.S. Highway I-205, Assessor Map 1S 2E 16AB;

402. Thence easterly along a line that is 100.00 feet south of the centerline of S.E. Holgate Boulevard to the point of beginning, Assessor Map 1S 2E 16AB.

TRACT 3

Beginning at a point on the east right-of-way line of U.S. Highway I-205, which is also the west right-of-way line of S.E. 96th Avenue, said point of beginning bearing South 03°24'00" West, a distance of 50.00 feet and South 86°36'00" East, a distance of 61.25 feet from the southwest corner of Lot "C" as shown in the plat of "School Park", said southwest corner being on the centerline of the right-of-way shown in said plat, Assessor Map 1S 2E 16AC:

403. Thence southerly along the east right-of-way line of U.S. Highway I-205, which is also the west right-of-way line of S.E. 96th Avenue to a line that is 100.00 feet north of the centerline of S.E. Harold Street, Assessor Map 1S 2E 16AC;
404. Thence westerly along a line that is 100.00 feet north of the centerline of S.E. Harold Street to a point that bears South 86°27'32" East, a distance of 92.18 feet and North 03°32'28" East, a distance of 70.00 feet from the intersection of the north right-of-way line of S.E. Harold Street with the west right-of-way line of U.S. Highway I-205, Assessor Map 1S 2E 16AC;
405. Thence North 03°03'50" East, a distance of 474.17 feet, Assessor Map 1S 2E 16AC;
406. Thence South 86°36'00" East, a distance of 420.71 feet to the point of beginning, Assessor Map 1S 2E 16AC.

TRACT 4

Beginning at a point of intersection of a line that is 100.00 feet south of the centerline of S.E. Harold Street with the east right-of-way line of U.S. Highway I-205 as shown in ODOT Drawing 9B-1-25, Assessor Map 1S 2E 16DB:

407. Thence southerly along the east right-of-way line of U.S. Highway I-205 as shown in ODOT Drawing 9B-1-25 to the north right-of-way line of S.E. Knight Street as shown in the plat of "Clemson Addition", Assessor Map 1S 2E 16DB;

408. Thence southeasterly to the intersection of a line that is 25.00 feet south of the north right-of-way line of S.E. Knight Street as shown in the plat of "Clemson Addition" with the west right-of-way line of an unnamed street that runs southerly from S.E. Knight Street to S.E. Yukon Street, Assessor Map 1S 2E 16DB;
409. Thence southerly along the west right-of-way line of an unnamed street that runs southerly from S.E. Knight Street to S.E. Yukon Street to a line that is 200.00 feet northerly of the centerline of S.E. Foster Road, Assessor Map 1S 2E 16DB;
410. Thence westerly along a line that is 200.00 feet northerly of the centerline of S.E. Foster Road to a point that bears South $67^{\circ}13'34''$ East, a distance of 66.56 feet and North $22^{\circ}46'26''$ East, a distance of 166.00 feet from the intersection of the north right-of-way line of S.E. Foster Road, said right-of-way line being 34.00 feet from the centerline thereof, with the west right-of-way line of U.S. Highway I-205, Assessor Map 1S 2E 16DB;
411. Thence North $09^{\circ}01'08''$ East, a distance of 391.27 feet, Assessor Map 1S 2E 16DB;
412. Thence North $03^{\circ}30'20''$ East, a distance of 546.46 feet to a line that is 100.00 feet south of the centerline of S.E. Harold Street to a point that bears South $86^{\circ}27'32''$ East, a distance of 88.09 feet and South $03^{\circ}32'28''$ West, a distance of 70.00 feet from the intersection of the south right-of-way line of S.E. Harold Street with the west right-of-way line of U.S. Highway I-205, Assessor Map 1S 2E 16DB;
413. Thence easterly along a line that is 100.00 feet south of the centerline of S.E. Harold Street to the point of beginning, Assessor Map 1S 2E 16DB.

TRACT 5

Beginning at a point on a line that is 200.00 feet southerly from the centerline of S.E. Woodstock Boulevard, said point of beginning bearing North $68^{\circ}14'41''$ West, a distance of 136.00 feet and South $21^{\circ}45'19''$ West, a distance of 16.15 feet from the northwest corner of Lot 1 as shown in the plat of "Mount Scott Acres", Assessor Map 1S 2E 16DC:

414. Thence South $15^{\circ}41'17''$ East, a distance of 45.32 feet, Assessor Map 1S 2E 16DC;



415. Thence South $07^{\circ}17'48''$ West, a distance of 631.15 feet, Assessor Map 1S 2E 16DC and Assessor Map 1S 2E 21AB;
416. Thence South $06^{\circ}40'40''$ West, a distance of 528.05 feet, Assessor Map 1S 2E 21AB;
417. Thence South $00^{\circ}38'26''$ West, a distance of 293.93 feet, more or less, to a point on a line that is 150.00 feet northerly of the centerline of the Springwater Corridor, said point bearing South $50^{\circ}35'13''$ West, a distance of 332.20 feet and North $39^{\circ}24'47''$ West, a distance of 100.00 feet from the most easterly corner of Lot 5 as shown in the plat of "Mount Scott Acres, Amended Plat of Lots 10, 11, 12, 13, 14, 15, 16, 17, 23 and A" , Assessor Map 1S 2E 21AB;
418. Thence South $50^{\circ}35'13''$ West, along a line that is 150.00 feet northerly from the centerline of the Springwater Corridor, a distance of 247.76 feet, Assessor Map 1S 2E 21AB;
419. Thence North $02^{\circ}24'38''$ West, a distance of 1,102.39 feet, Assessor Map 1S 2E 21AB;
420. Thence North $07^{\circ}18'40''$ West, a distance of 255.66 feet, Assessor Map 1S 2E 16DC;
421. Thence North $09^{\circ}25'57''$ West, a distance of 489.58 feet, more or less to a line that is 200.00 feet southerly from the centerline of S.E. Woodstock Boulevard, Assessor Map 1S 2E 16DC;
422. Thence South $68^{\circ}14'41''$ East, along a line that is 200.00 feet southerly from the centerline of S.E. Woodstock Boulevard, a distance of 520.20 feet to the point of beginning.

TRACT 6

Beginning at a point on a line that is 150.00 feet southerly of the centerline of the Springwater Corridor, said point bearing South $50^{\circ}35'13''$ West, a distance of 567.89 feet and South $39^{\circ}24'47''$ East, a distance of 200.00 feet from the most easterly corner of Lot 5 as shown in the plat of "Mount Scott Acres, Amended Plat of Lots 10, 11, 12, 13, 14, 15, 16, 17, 23 and A" , Assessor Map 1S 2E 21AB and Assessor Map 1S 2E 21AC;



- 423. Thence South 00°05'12" West, a distance of 416.97 feet to a point of curvature, Assessor Map 1S 2E 21AC;
- 424. Thence along the arc of a 5,205.00 foot radius curve, concave westerly, through a central angle of 08°14'41", the long chord of which bears South 02°12'32" West, a distance of 748.34 feet, an arc distance of 748.99 feet, Assessor Map 1S 2E 21AC;
- 425. Thence North 85°28'50" West, non-tangent to the last described course, a distance 205.47 feet to a point of non-tangent curvature, the radial center of which bears North 81°30'44" West, Assessor Map 1S 2E 21AC;
- 426. Thence along the arc of a 5,000.00 foot radius curve, concave westerly, through a central angle of 08°24'05", the long chord of which bears North 04°17'14" East, a distance of 733.15 feet, an arc distance of 732.49 feet to a point of tangency, Assessor Map 1S 2E 21AC;
- 427. Thence North 00°05'12" East, a distance of 247.04 feet, more or less, to a line that is 150.00 feet southerly of the centerline of the Springwater Corridor, said point bearing South 50°35'13" West, a distance of 45.99 feet and South 39°24'47" East, a distance of 200.00 feet from the southeast corner of Lot 8 as shown in the plat of "Laurinville" , Assessor Map 1S 2E 21AB and Assessor Map 1S 2E 21AC;
- 428. Thence North 50°35'13" East, along a line that is 150.00 feet southerly of the centerline of the Springwater Corridor, a distance of 265.67 feet to the point of beginning, Assessor Map 1S 2E 21AB and Assessor Map 1S 2E 21AC.



RENEWAL: DECEMBER 31, 2009





9755 SW Barnes Rd., Suite 300
Portland, OR 97225
503-626-0455 Fax 503-526-0775
www.whpacific.com

LENTS TOWN CENTER URA
2,918 ACRES
MAY 2, 2008

SHEET 2

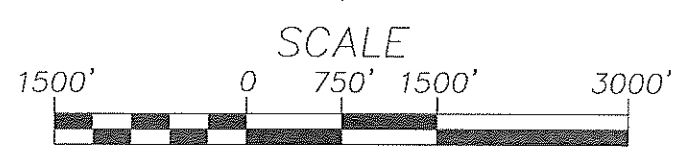
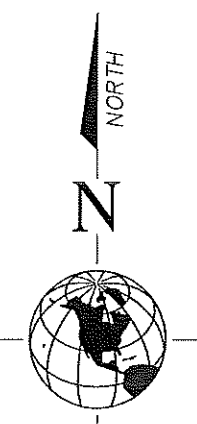
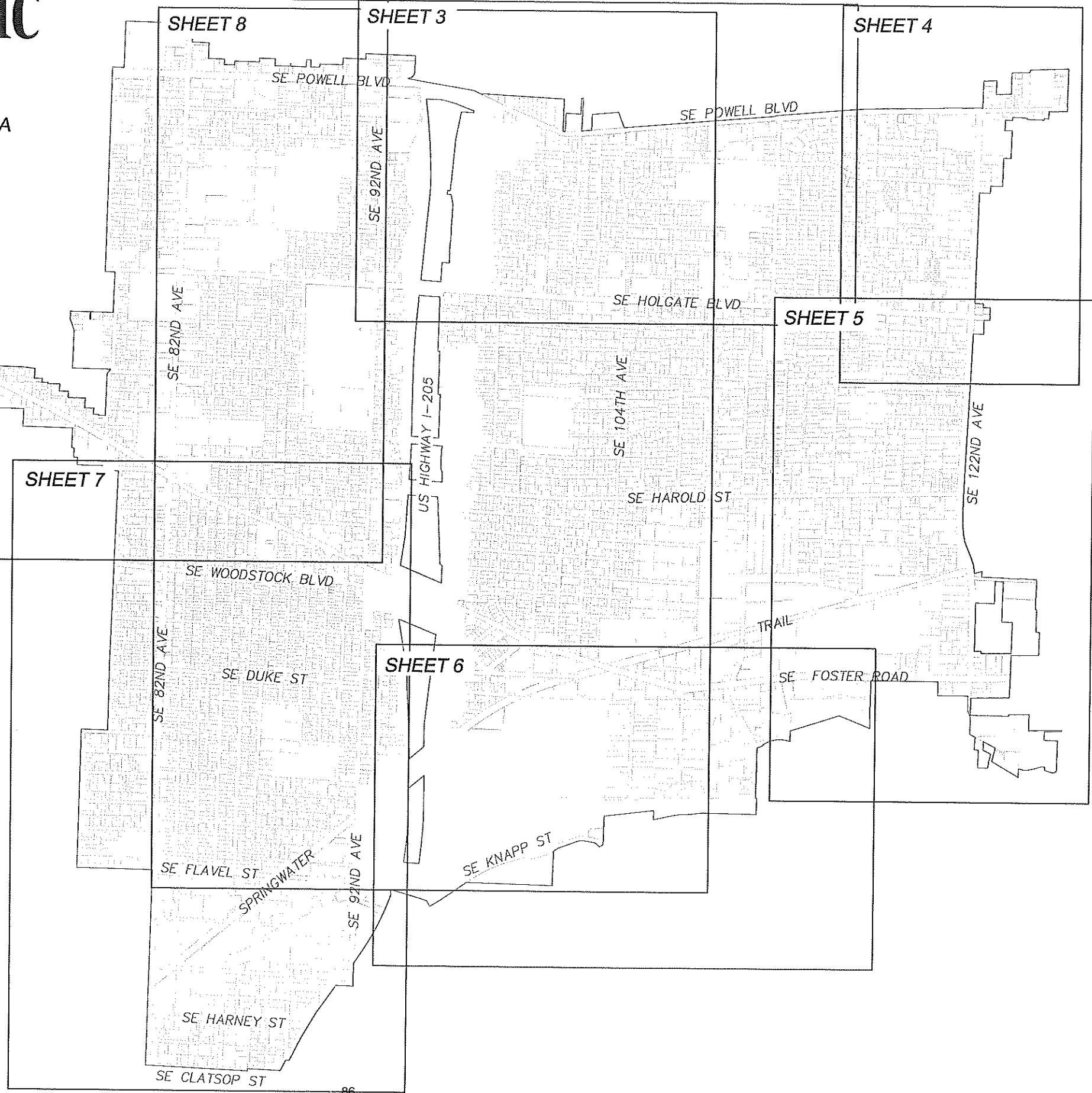
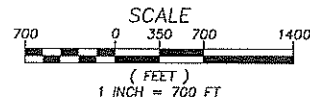
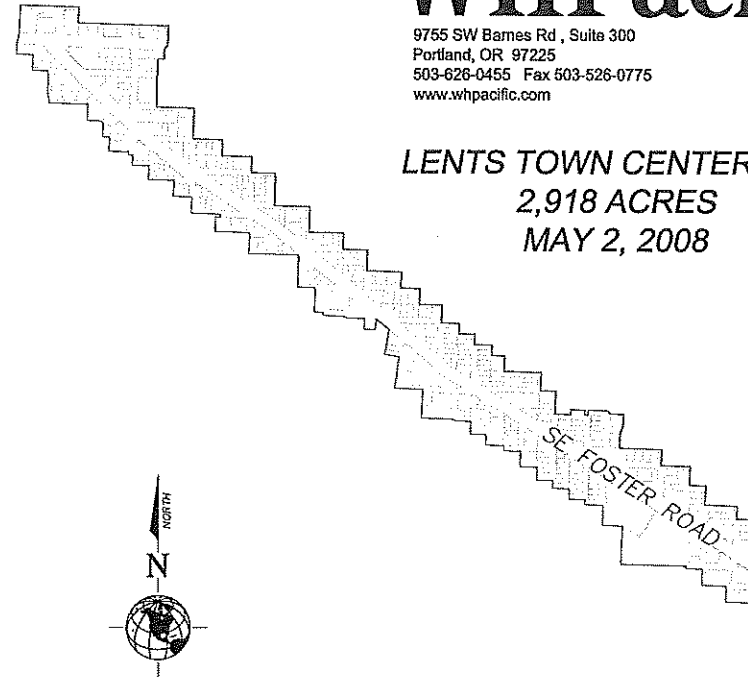
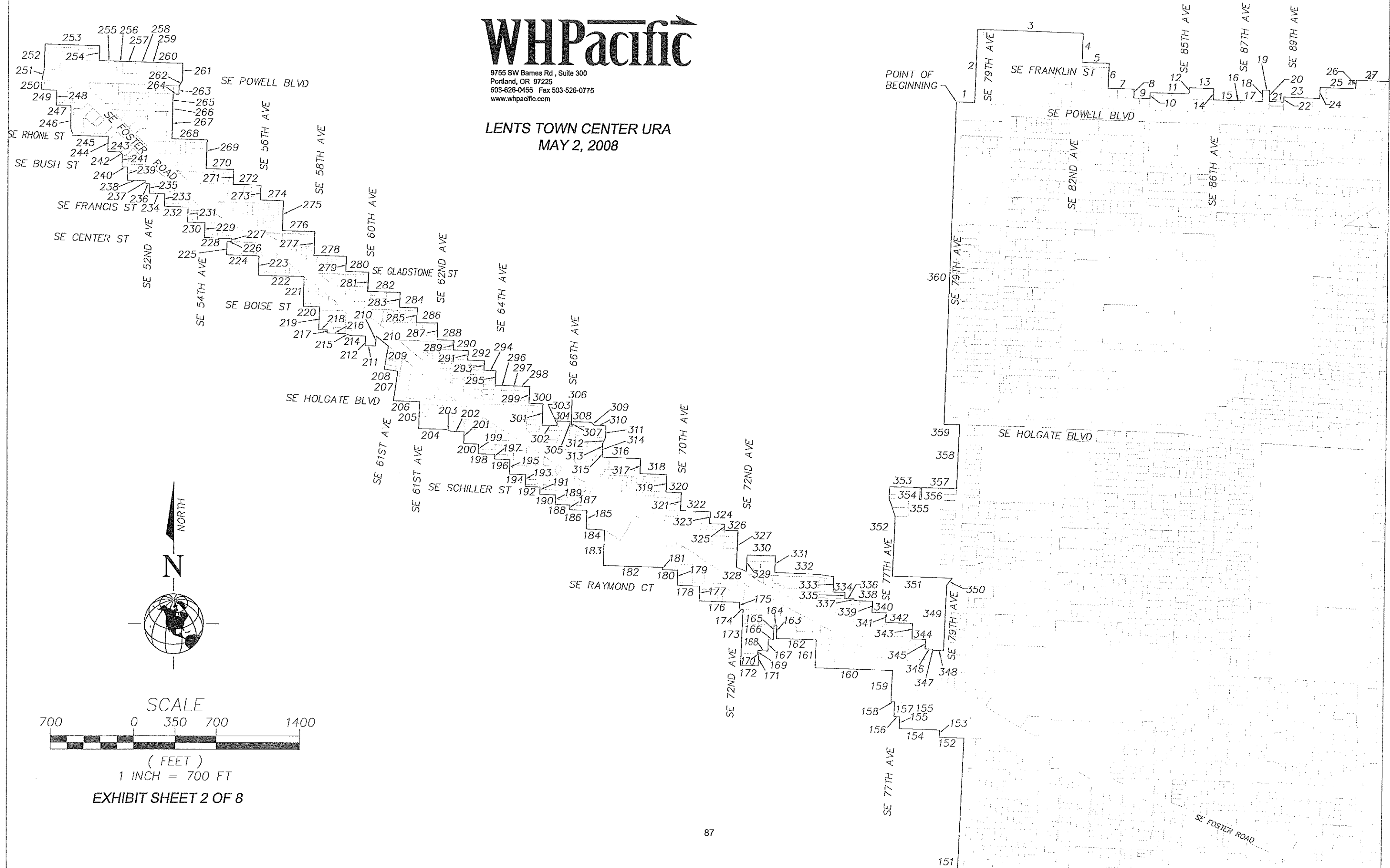

EXHIBIT INDEX PAGE
SHEET 1 OF 8



9755 SW Barnes Rd., Suite 300
Portland, OR 97225
503-626-0455 Fax 503-526-0775
www.whpacific.com

LENTS TOWN CENTER URA
MAY 2, 2008



WHPacific

9755 SW Barnes Rd, Suite 300
Portland, OR 97225
503-628-0455 Fax 503-526-0775
www.whpacific.com

LENTS TOWN CENTER URA
MAY 2, 2008

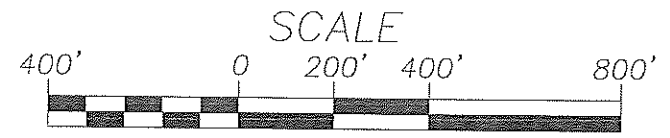
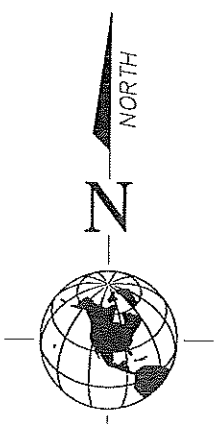

1 INCH = 400 FT
SHEET 3 OF 8

WHPacific

9755 SW Barnes Rd , Suite 300
Portland, OR 97225
503-626-0455 Fax 503-526-0775
www.whpacific.com

LENTS TOWN CENTER URA
MAY 2, 2008

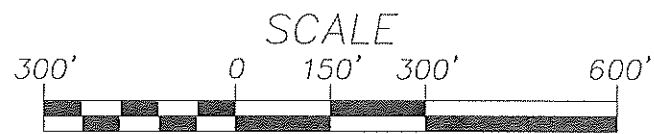
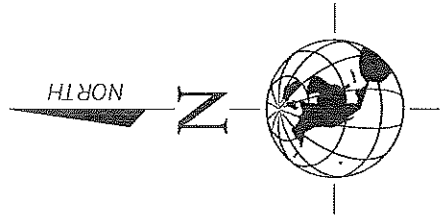
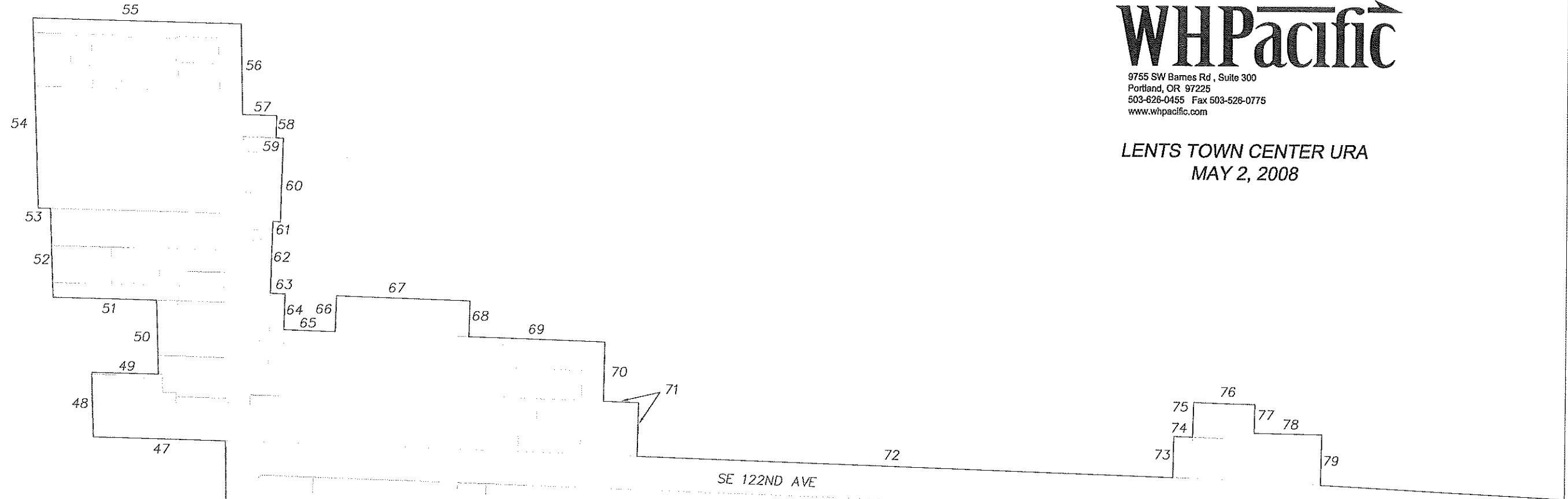

SCALE
(FEET)
1 INCH = 300 FT
SHEET 4 OF 8

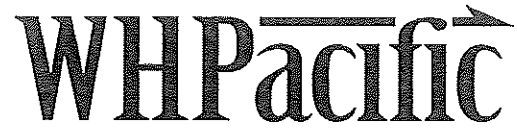

9755 SW Barnes Rd., Suite 300
Portland, OR 97225
503-626-0455 Fax 503-528-0775
www.whpacific.com

LENTS TOWN CENTER URA
MAY 2, 2008

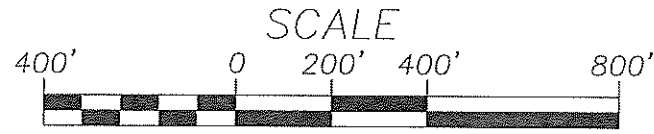
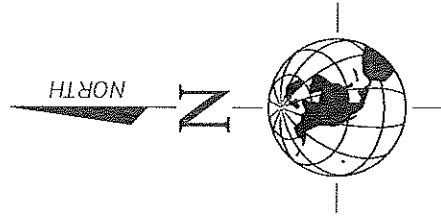

SCALE
(FEET)
1 INCH = 400 FT
SHEET 5 OF 8

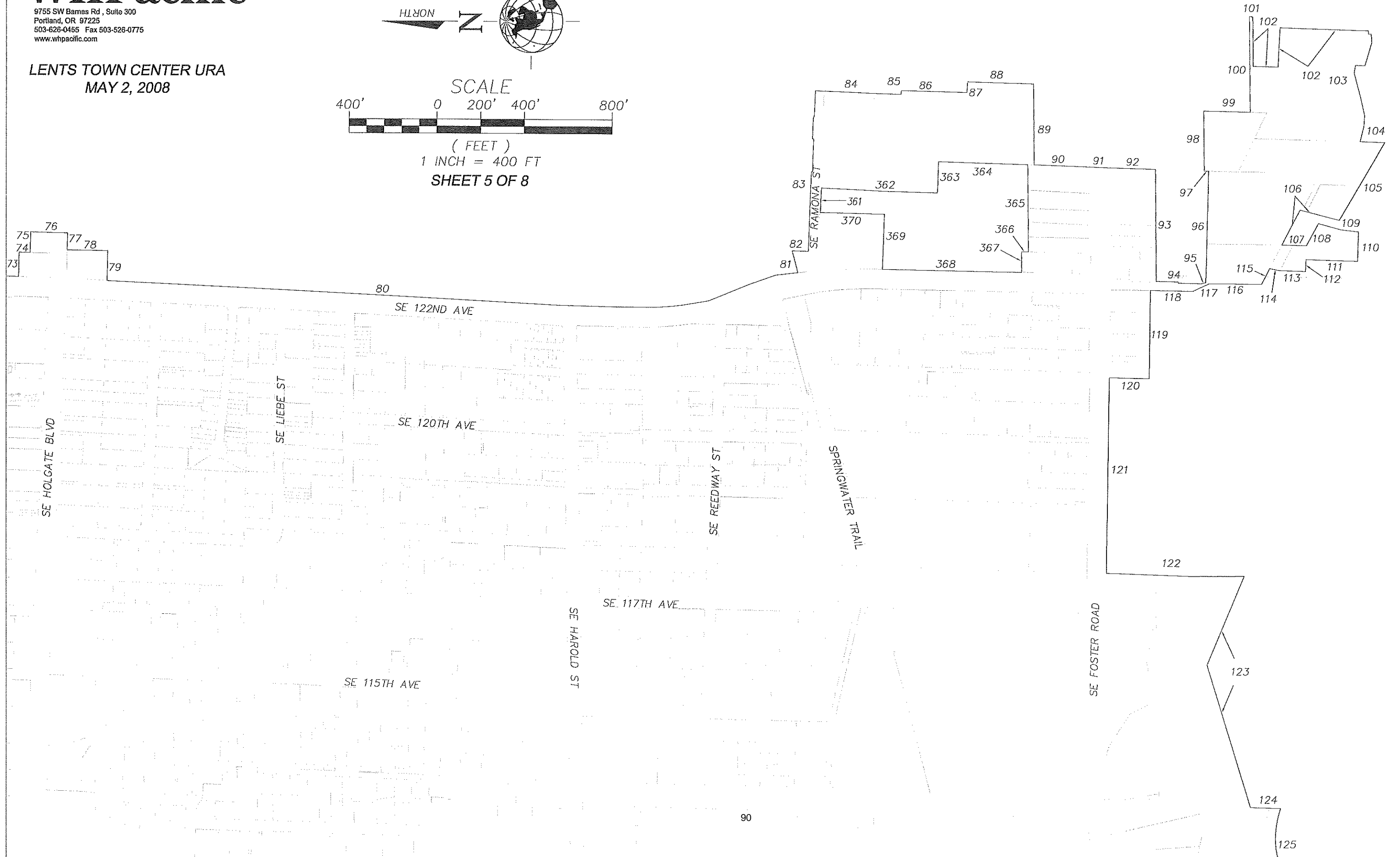

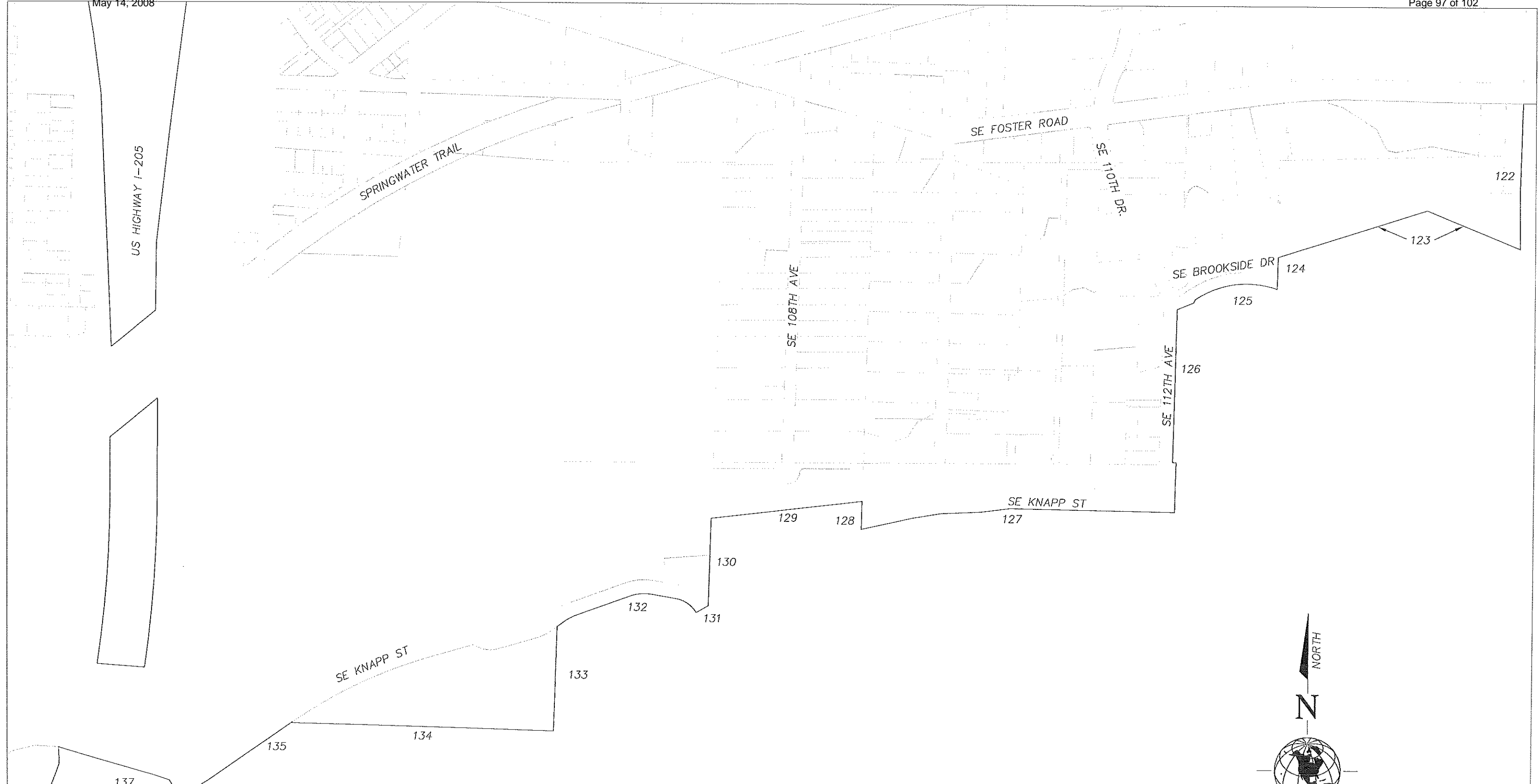

WHPacific

9755 SW Barnes Rd., Suite 300
Portland, OR 97225
503-626-0455 Fax 503-526-0775
www.whpacific.com

LENTS TOWN CENTER URA
MAY 2, 2008 91

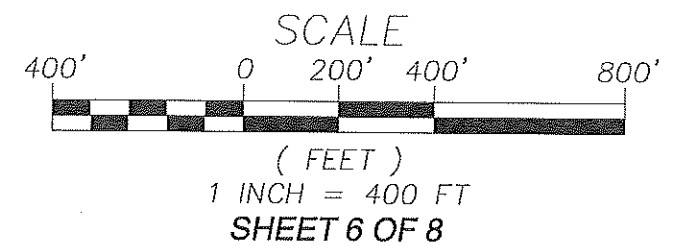
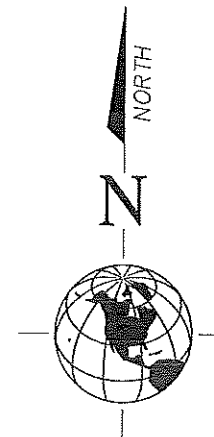

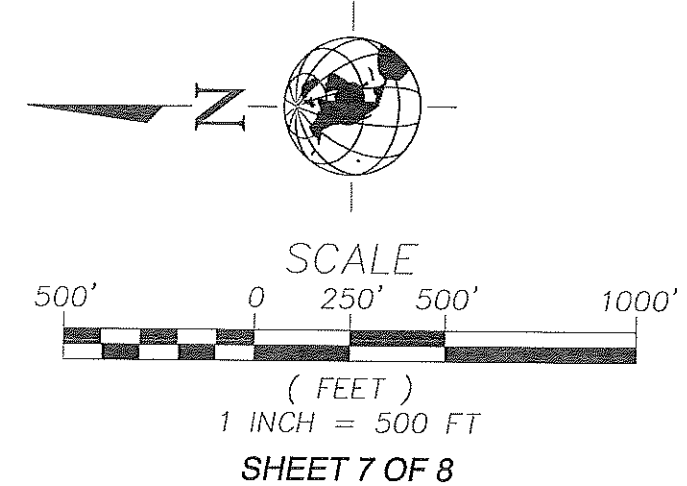

WHPacific
 9755 SW Barnes Rd, Suite 300
 Portland, OR 97225
 503-626-0455 Fax 503-528-0775
 www.whpacific.com



9755 SW Barnes Rd., Suite 300
Portland, OR 97225
503-626-0455 Fax 503-526-0775
www.whpacific.com

LENTS TOWN CENTER URA
MAY 2, 2008

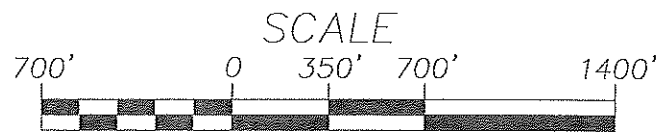
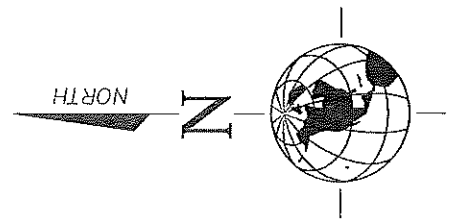
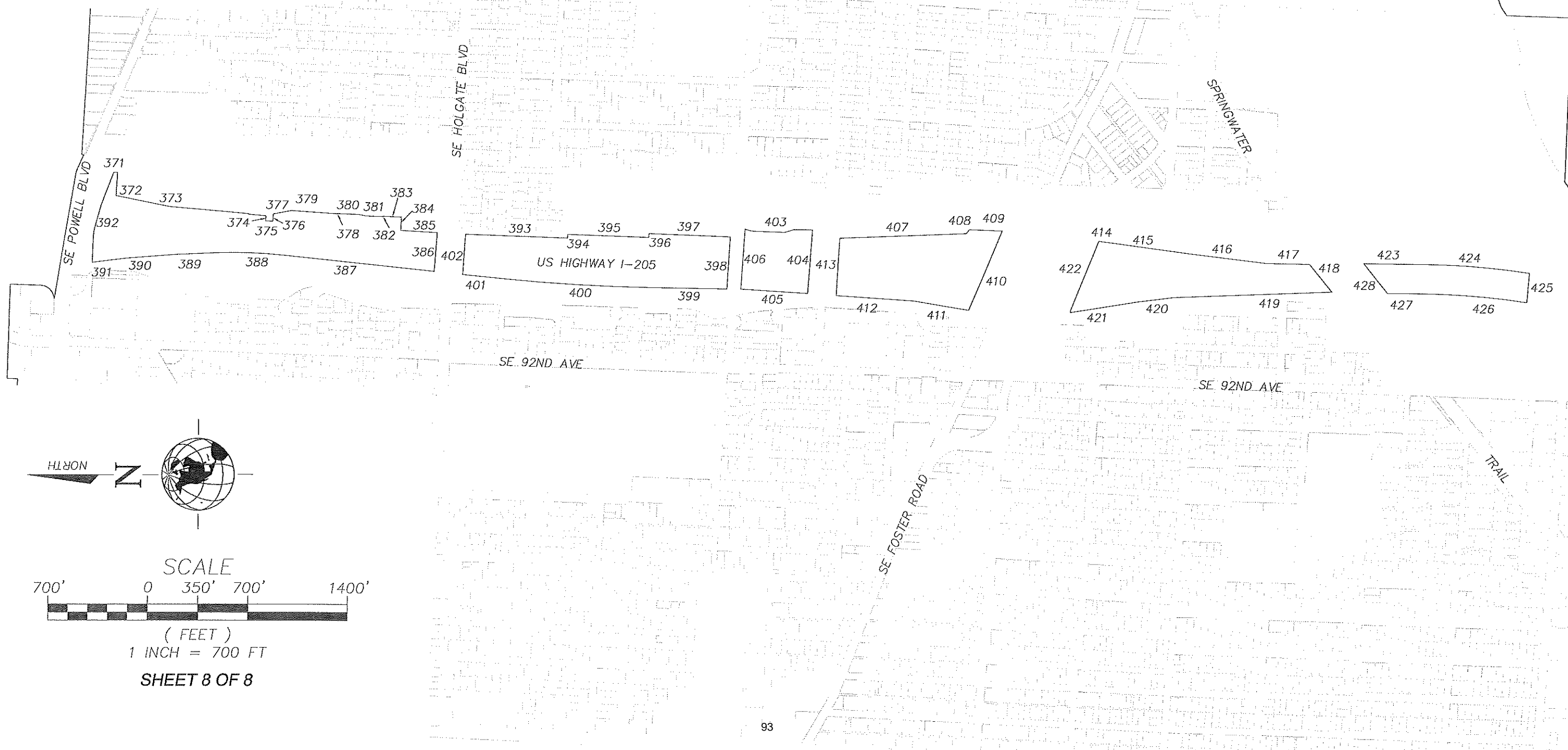

(FEET)
1 INCH = 700 FT
SHEET 8 OF 8

Exhibit B. Comprehensive Plan Map

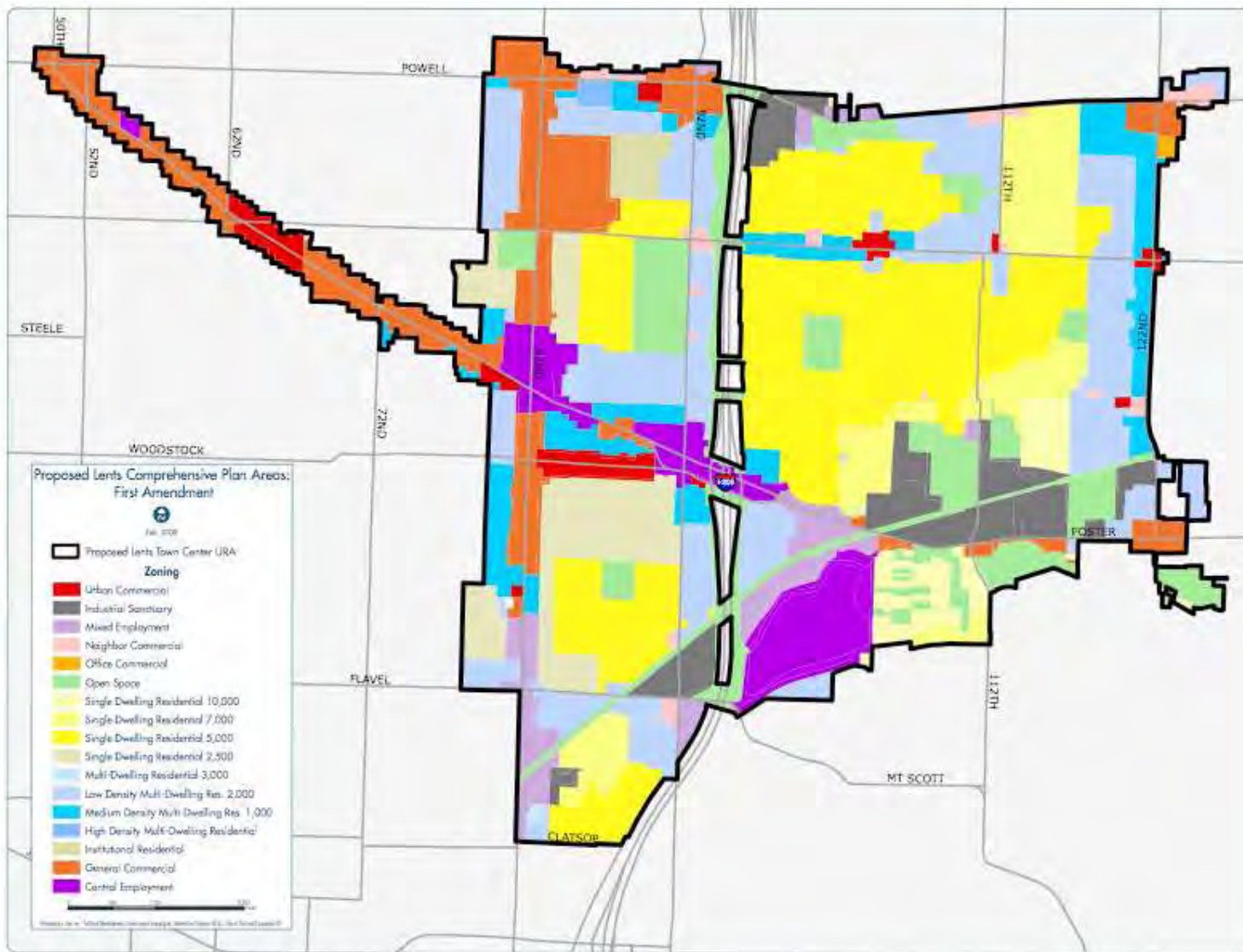
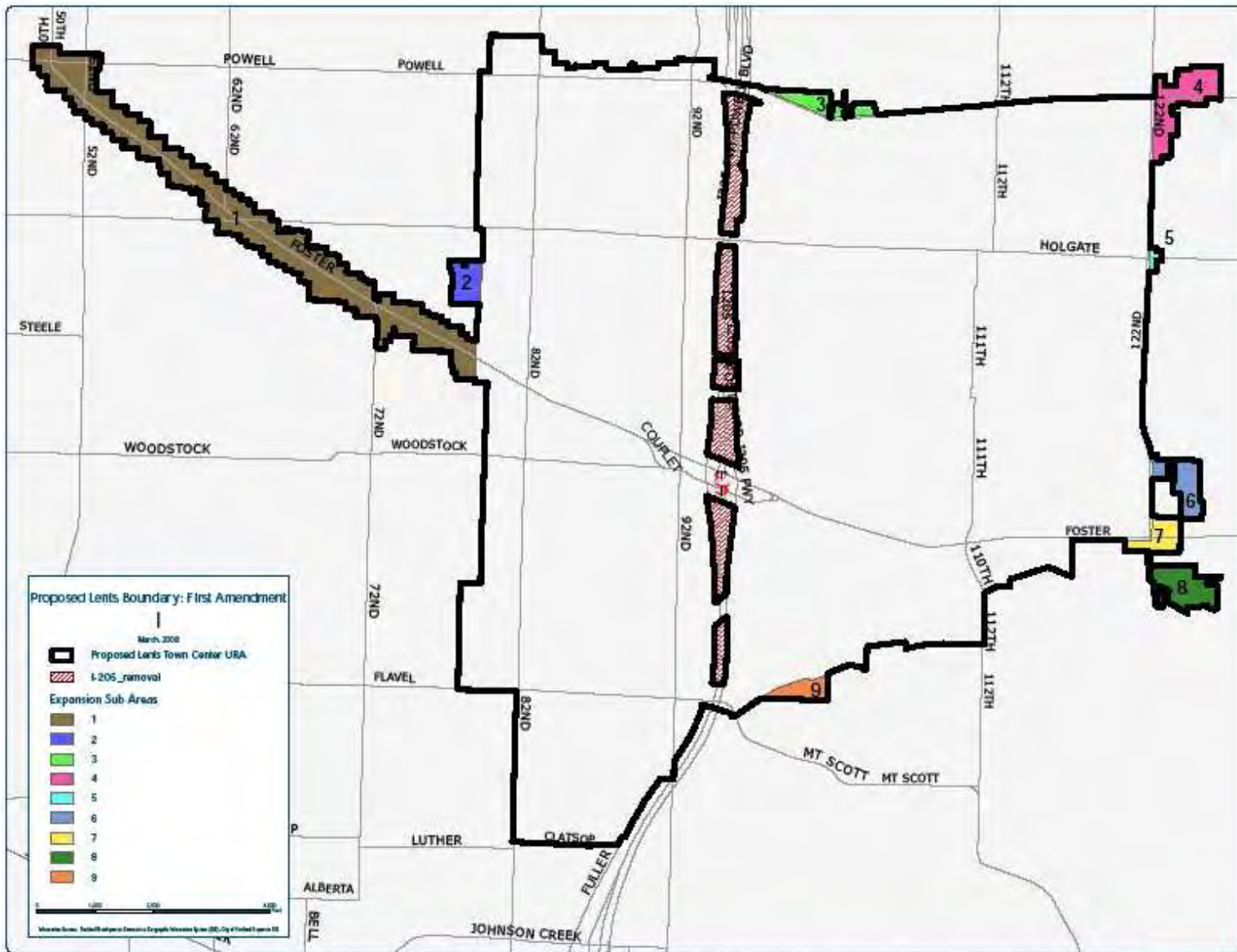
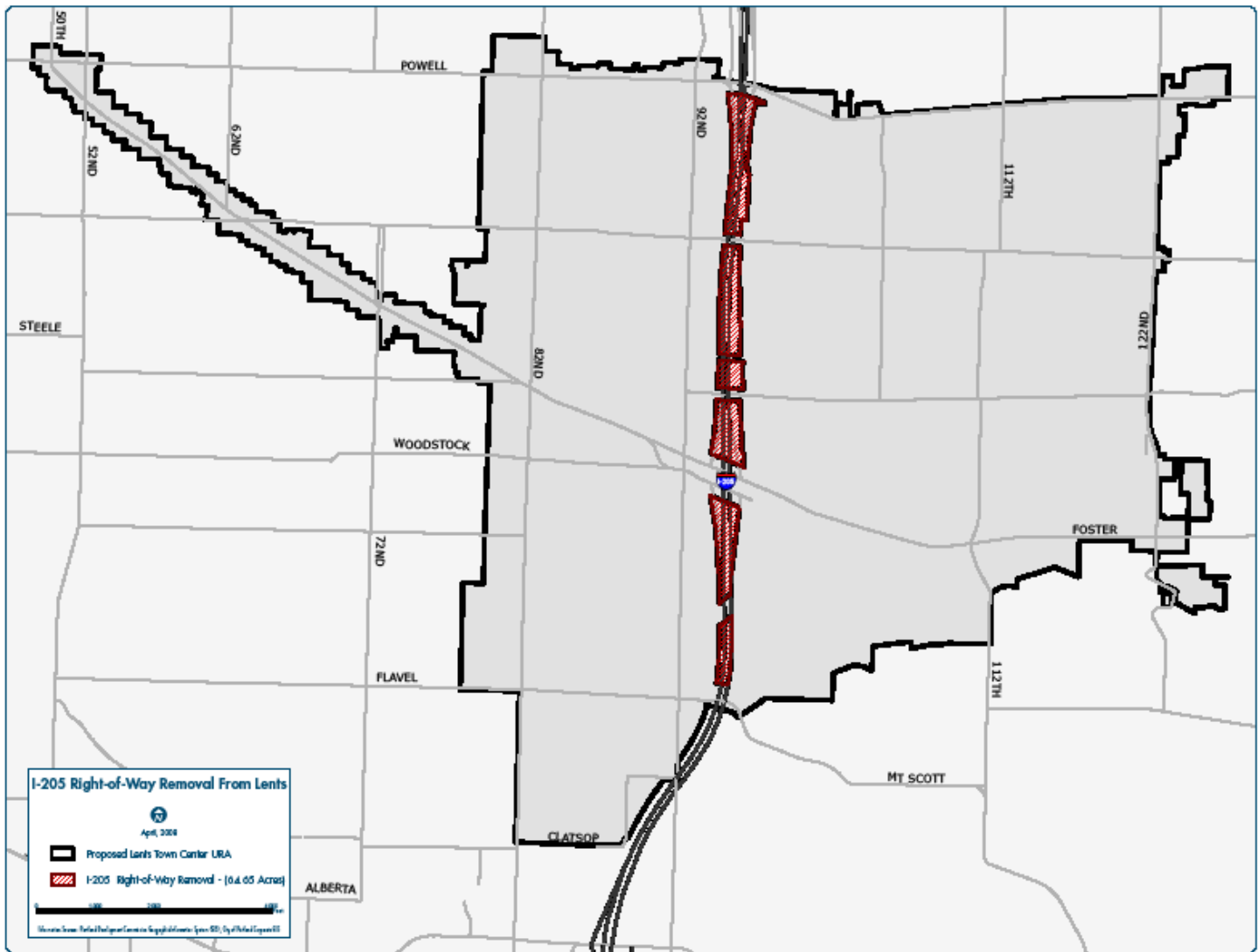

Exhibit I. Expansion Areas



The information on this map was created by the Portland Development Commission (PDC) GIS. Every reasonable effort has been made to ensure the accuracy of these maps and associated data. However, no warranty is made by the PDC or any other party regarding the accuracy or completeness of this information. It is provided "as is" and all other warranties, either registered or implied, are hereby disclaimed.

Exhibit II. Deletion Areas



The information on this map was created by the Portland Development Commission (PDC) GIS. Every reasonable effort has been made to ensure the accuracy of these maps and associated data. However, inadvertent errors can occur and the PDC does not assume any responsibility for omissions or partial accuracy. This information is presented "as is" and without warranty, either expressed or implied.